

14T968DC

Instruction Book

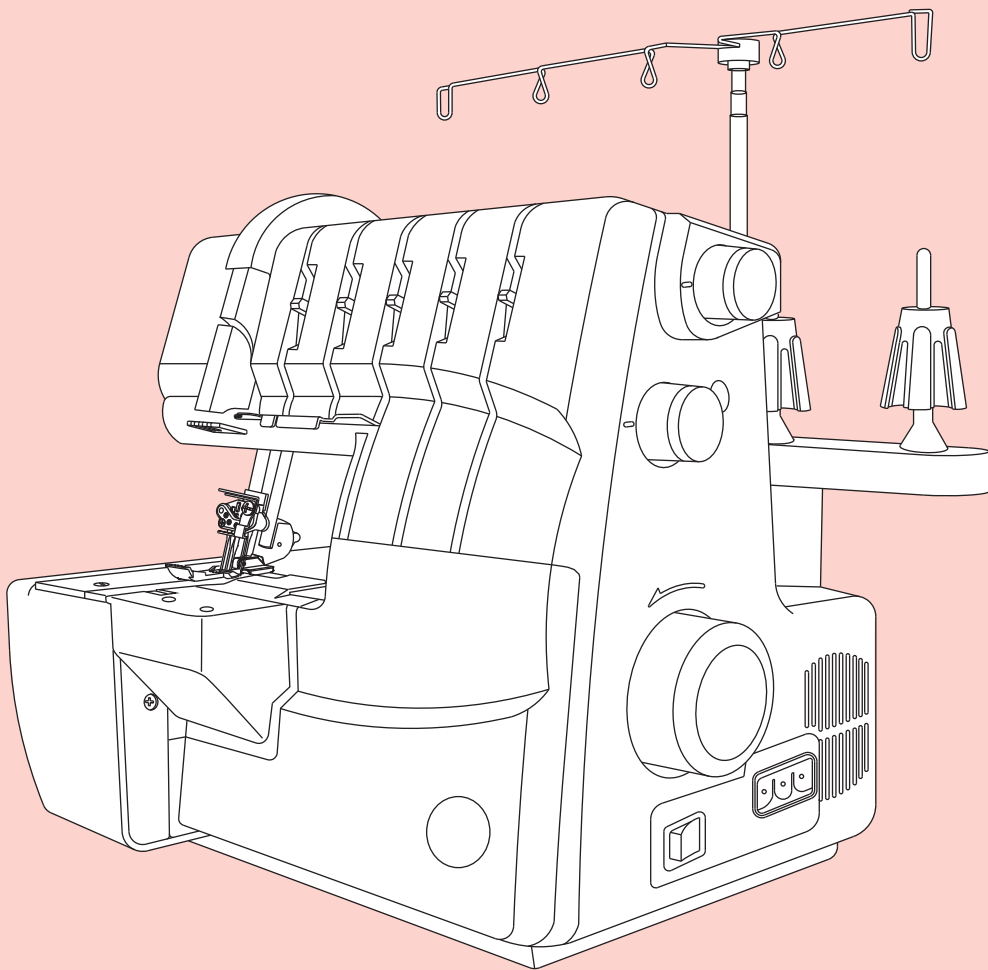

SINGER[®]
AT HOME WORLDWIDE

14T968DC

PREFACE

Thank you for your purchase of this Combination Overlock, Chain Stitch and Cover Stitch Sewing Machine. This machine, that is intended for household use, will provide you with excellent performance in sewing from light to heavy material (lawn to denim).

Please refer to this Instruction Book for proper use and optimum service. To get the most out of your sewing machine, read the entire Instruction Book before attempting to operate the machine. Then familiarize yourself with the machine by following the Instruction Book page by page.

To ensure that you are always provided with the most modern sewing capabilities, the manufacturer reserves the right to change the appearance, design or accessories of this sewing machine when considered necessary without notification or obligation.

This SINGER sewing machine, model 14T968DC, has been tested by GS (Certification of Electro-technical Materials) according to European standards, and corresponds to the guidelines for electrical safety, radio interference and surge immunity. Conformity is documented by the GS symbol and the CE identification.



SINGER® is a registered trademark of The Singer Company Limited or its affiliates.
©2008 The Singer Company Limited or its affiliates. All rights reserved.

IMPORTANT SAFETY INSTRUCTIONS

When using this machine, basic safety precautions should always be followed including the following. Read all instructions before using the machine.



DANGER -To reduce the risk of electric shock:

- * The machine should never be left unattended when plugged in. Always unplug the machine from the electric outlet immediately after using and before cleaning.
- * Always unplug before re-lamping. Replace bulb with the same type rated 15 watts. Be sure to replace the face plate which covers the light bulb before operating the machine.



WARNING -To reduce the risk of burns, fire, electric shock or injury to persons:

- * Be sure that the electrical voltage of the electric outlet (wall receptacle) is the same as the rated voltage of the motor.
- * Use this machine only for its intended use as described in this Instruction Book. Use only attachments recommended by the manufacturer as contained in the Instruction Book.
- * To disconnect, turn all controls to the off ("0") position, then remove plug from outlet.
- * Disconnect the power line plug from the socket outlet or switch the machine off when making any adjustments in the needle area, such as threading needle and loopers, changing needle, changing throat plate or changing presser foot, etc.
- * Always unplug the machine from the electrical outlet when removing covers, lubricating, or when making any other user servicing adjustments mentioned in the Instruction Book.
- * Do not attempt to adjust the motor belt. Contact your nearest Service Center should any adjustment be required.
- * Handle the foot controller with care and avoid dropping it on the floor. Be sure not to place anything on top of the controller.
- * Always use the proper needle plate. The wrong plate can cause the needle to break.
- * Do not use bent needles.
- * When sewing, keep fingers away from all moving parts. Special care is required around the sewing machine needle.
- * Do not pull or push fabric while stitching. It may deflect the needles causing them to break.
- * For double insulated machines, when servicing, use only identical replacement parts. See instructions for Servicing of Double-Insulated Appliances.
- * Never operate the machine if it has a damaged cord or plug, if it is not working properly, if it has been dropped or damaged, or dropped into the water. Return the machine to the nearest authorized dealer or Service Center for examination, repair, electrical, or mechanical adjustment.
- * Never operate the machine with any air openings blocked. Keep ventilation openings of the machine and foot controller free from the accumulation of lint, dust and loose cloth.
- * Never drop or insert any object into any opening.

- * Do not use outdoors.
- * Do not operate where aerosol (spray) products are being used or where oxygen is being administered.
- * Do not allow to be used as a toy. Close attention is necessary when the machine is used by or near children.
- * Do not expose the machine or machine plastic case to sunlight directly. Also, do not keep it in a very warm or damp place.
- * Do not touch the machine, foot controller and power line cord with wet hand, wet cloth or with anything wet.
- * Do not connect power line cord to one of the many cords connected to one power outlet with adapters.
- * Use machine on flat and stable table.
- * Be sure to close the looper cover before operating the machine.
- * Keep presser foot and needles away from children's reach.
- * Be sure the light bulb has cooled off before changing with a new one.
- * Do not dismantle or modify the machine yourself.
- * Be sure to turn off the power switch and disconnect the power line plug before caring for your machine as instructed in the Instruction Book.
- * The appliance is not intended for use by young children or infirm persons without supervision.
- * Young children should be supervised to ensure that they do not play with the appliance.
- * Do not unplug by pulling on cord. To unplug, grasp the plug, not the cord.
- * **SERVICING OF DOUBLE-INSULATED PRODUCTS.** In a double-insulated product, two systems of insulation is provided instead of grounding. No grounding means is provided on a double-insulated product, nor should a means for grounding be added to the product. Servicing of a double-insulated product requires, extreme care and knowledge of the system, and should be done only by qualified service personnel. Replacement parts for a double-insulated product must be identical to those parts in the product. A double-Insulated product is marked with the word "DOUBLE-INSULATION" or "DOUBLE-INSULATED".

TABLE OF CONTENTS

	Page		Page
1. Selection stitches & Auto tension.....	5	21. Chaining Off and Test Sewing.....	38
2. Handy Reference Chart.....	8	22. Settings and Sewing Instructions.....	39
3. Accessories.....	9	1) Double chain stitch.....	39
4. Needle Information.....	9	2) 2-Thread Wrapped Edge Overlock.....	41
5. Principal Parts.....	10	3) 2-Thread Overedge.....	42
6. How to Open Looper Cover.....	12	4) 3-Thread Overlock.....	43
7. Principal Parts Behind Looper Cover.....	12	5) 3-Thread Flatlock.....	44
8. Preparation prior to sewing.....	12	6) 3-Thread Ultra Stretch Mock Safety Stitch.....	45
9. Removal and Replacement of Waste Tray.....	13	7) 4-thread Ultra Stretch Mock Safety Stitch.....	46
10. Preparation for Threading.....	14	8) 4-Thread Safety Stitch.....	47
*Setting up the thread guide holder.....	14	9) 5-Thread Safety Stitch.....	48
*Anti-spill net.....	14	23. How to Sew a Cover Stitch.....	49
*Spool cap.....	14	24. How to Sew a Rolled hem.....	54
11. How to Remove and Insert Needles.....	15	1) 3-thread standard rolled hem stitching.....	55
*Needle position.....	15	2) 3-thread upper looper thread wrapped	
*To remove needle(s).....	15	rolled hem stitching.....	55
*To insert needle(s).....	15	3) 2-thread standard rolled hem stitching.....	56
12. Threading the Machine.....	16	4) 2-thread lower looper thread wrapped	
*Threading diagram.....	16	rolled hem stitching.....	56
*Understanding the color code.....	16	25. Stitch Variations and Sewing Techniques.....	58
*To thread the machine correctly.....	17	*Decorative Flatlocking.....	59
1) Threading the upper looper (Green).....	17	*How to sew an overlock blind hem.....	60
2) Threading the lower looper (Red).....	18	*How to sew pin tucks.....	60
3) Threading the chain stitch looper (Brown).....	20	*Turning square corners.....	61
4) Threading the overedge right needle (Blue).....	21	*Pin placement.....	62
5) Threading the chain stitch needle (Orange).....	23	*Securing the thread chain.....	62
6) Threading the cover stitch needles.....	25	*How to reinforce a seam.....	63
① Threading the cover stitch left needle (Orange) 25		*Braiding by chaining off.....	63
② Threading the cover stitch middle/chain stitch		26. Machine Maintenance.....	64
needle(Blue).....	26	*Cleaning the machine.....	64
③ Threading the cover stitch right needle(Green). 28		*Oiling the machine.....	64
13. How to Change Threads / Tie on Method.....	30	*How to replace the moveable upper knife.....	65
14. How to Adjust the Stitch length.....	31	*How to exchange light bulb.....	66
15. How to Adjust the Seam width.....	31	27. Optional Accessories.....	67
*Width adjustment by changing needle position.....	31	*Snap-on type presser foot.....	67
*Width adjustment with adjustment knob.....	31	*Optional presser feet.....	68
16. How to Adjust the Presser Foot Pressure.....	32	1) Elastic foot.....	68
17. Differential Feed.....	33	2) Blind hem foot.....	68
*Gathered overedge.....	33	3) Shirring foot.....	68
*Stretch overedge.....	34	4) Pearl/Sequin foot.....	68
18. How to Disengage Movable Upper Knife.....	35	5) Piping/Cording foot.....	68
19. To Convert upper Looper to Spreader.....	36	6) Taping foot.....	68
*To use the spreader.....	36	28. Troubleshooting Chart.....	69
*To disengage to upper looper.....	36	29. Relationship between Cloth, Thread and Need..	70
20. Standard overedge and Rolled Hem Stitching.....	37	30. Specification.....	71
*To sew standard overedge.....	37		
*To sew rolled hem.....	37		

1. SELECTION OF STITCHES & AUTO TENSION

This machine is capable of producing various types of stitches according to the combination of Auto Tension Selected, needle positions, threading methods, and the use of convertible right looper/spreader.

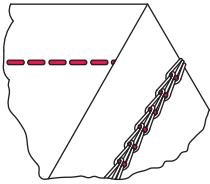
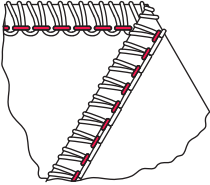
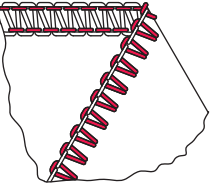
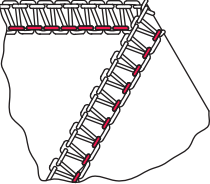
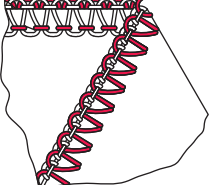
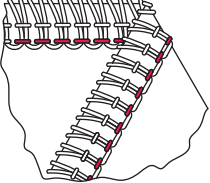
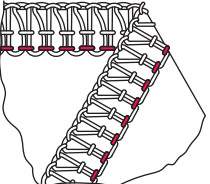
Stitch Type	ATD : Auto Tension Dial Selected	Reference Page
1. Double Chain Stitch ATD: D		A 1-needle 2-thread straight stitch is used for construction or decorative stitching. Seams also can be sewn at desired distance from edge of fabric by disengaging the right looper and movable knife. 39
2. Two-thread Wrapped Edge Overlock ATD: D ATD: G		1-needle 2-thread stitch is used for seaming lightweight or stretch fabrics. It is also ideal for rolled and blind hemming. A 4 mm and 6 mm overlock seam width can be obtained by changing the needle position. 41
3. Two-thread Overedge ATD: E		1-needle 2-thread stitch is used for overedging common fabrics. It is also ideal for flatlock (butted or lapped) seams and blind hemming. A 4 mm and 6 mm overedge seam width can be obtained by changing the needle position. 42
4. Three-thread Overlock ATD: A ATD: B		1-needle 3-thread stitch is used for overedging and seaming on common fabrics. A 4mm and 6 mm overlock seam width can be obtained by changing the needle position. 43
5. Three-thread Flatlock ATD: F		1-needle 3-thread stitch is used for butted or lapped seams and ornamental stitching with decorative thread. Also, a 4 mm and 6 mm flatlock width can be obtained by changing the needle position. 44
6. Three-thread Ultra-Stretch Mock Safety Stitch ATD: G		2-needle 3-thread stitch that is ideal for lightweight, extremely stretchy fabrics such as tricot and spandex. 45
7. Four-thread Ultra-Stretch Mock Safety Stitch ATD: A		2-needle 4-thread stitch that is ideal for medium to heavyweight stretchy fabrics such as double knits and swim Wear. 46

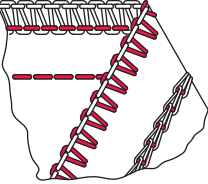
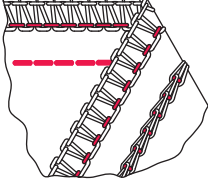
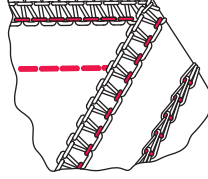
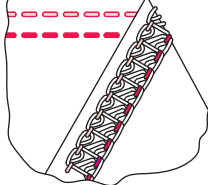
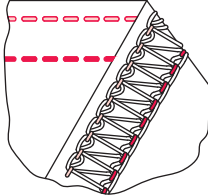
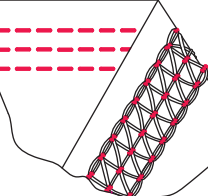
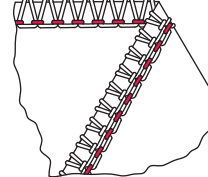





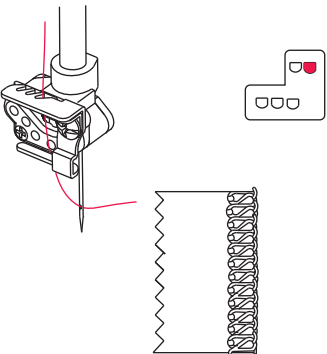
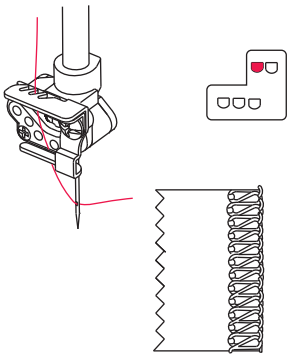











Stitch Type	ATD : Auto Tension Dial Selected	Reference Page
8. Four-thread Safety Stitch ATD: I		The 4-thread stitch is a safety stitch made up of combined 2-thread overedge and double chainstitch. 47
9. Five-thread Safety Stitch Wide ATD: B		The 5-thread stitch is a safety stitch made up of combined 3-thread overlock and double chainstitch. A wide seam is formed by using left needle. Overedge and seaming can be done in one operation on non-stretch fabrics. 48
10. Five-thread Safety Stitch Narrow ATD: A		The 5-thread stitch is a safety stitch made up of combined 3-thread overlock and double chainstitch. A narrow seam is formed by using right Needle. Overedge and seaming can be done in one operation on non-stretch fabrics. 48
11. Cover Stitch Narrow (2.8mm) ATD: K		2-needle, 3-thread cover stitch is suitable for stretchy fabrics such as knits, etc. A narrow seam is formed by using left and middle needles. 51
12. Cover Stitch Wide (5.6mm) ATD: H		2-needle 3-thread cover stitch is suitable for stretchy fabrics such as knits, etc. A wide seam is formed by using left and right needles. 51
13. Triple Cover Stitch (5.6mm) ATD: J		3-needle 4-thread cover stitch is suitable for stretchy fabrics such as knits, etc. A triple seam is formed by using left, middle, and right needles. 52
14. Three-thread Rolled Hem ATD: C		1-needle 3-thread stitch is used for sewing narrow rolled hems. 55

* Depending on the needle positions used, this machine can sew 2-thread and 3-thread standard width 4 mm overedge and a 6 mm wide overedge seams.

Also, for overedging heavyweight fabrics, the seam width can be increased still more by turning the overedge seam width adjustment knob. (See page 31)

Overedge width	4.0 mm	6.0 mm
Needle used	Overedge right needle	Overedge left needle
Needle thread tension fine tuning	Blue	Orange
		

2. HANDY REFERENCE CHART

	Stitch Type	A T D	S L	D F	L / C	Needle Position 	Correct Threading / Tension Path: When using the Auto Tension Dial (ATD), the correct tension is set automatically.					Page
							Orange	Blue	Green	Red	Brown	
1	Double Chain Stitch	D	N	N	C			●			●	39
2	Two - Thread Wrapped Edge Overlock	D	2	N	L	4.0mm 		●			●	41
		G	2	N	L	6.0mm 	●				●	41
3	Two - Thread Overedge	E	2	N	L	4.0mm 		●			●	42
		E	2	N	L	6.0mm 	●				●	42
4	Three - Thread Overlock	A	N	N	L	4.0mm 		●	●	●		43
		B	N	N	L	6.0mm 	●		●	●		43
5	Three - Thread Flatlock	F	2	N	L	4.0mm 		●	●	●		44
		F	2	N	L	6.0mm 	●		●	●		44
6	Three - Thread Ultra - Stretch mock Safety Stitch	G	2	N	L		●	●		●		45
7	four - Thread Ultra - Stretch mock Safety Stitch	A	N	N	L		●	●	●	●		46
8	Four - Thread Safety Stitch	I	N	N	L		●	●		●	●	47
9	Five - Thread Safety Stitch Wide	B	N	N	L		●	●	●	●	●	48
10	Five - Thread Safety Stitch Narrow	A	N	N	L		●	●	●	●	●	48
11	Cover stitch Narrow	K	N	N	C	2.8mm 	●	●			●	51
12	Cover stitch Wide	H	N	N	C	5.6mm 	●		●		●	51
13	Triple Cover stitch	J	N	N	C	5.6mm 	●	●	●		●	52
14	Three - Thread Rolled Hem	C	1	N	L	4.0mm 		●	●	●		55

ATD: Auto Tension Dial Selection

DF: Differential Feed

SL: Stitch Length

L / C: Upper Loper driving clutch position

*When option 2, 3, 6, 8 selected, use spreader.

*When option 1, 11, 12, 13 selected, turn upper knife down, move seam width finger knob to setting R, and change knife cover into seam guide plate.

*Auto tension settings are based on medium weight fabric and standard # 60 polyester spun thread. It can satisfy most requirements for sewing. If using a different thread weight or fabric and the result is not as you expected, please adjust tension in small increments.

3. ACCESSORIES

Accessories are contained in the accessory case

- | | |
|-------------------------------|----------------|
| 1. Screw driver (large size) | 1 |
| 2. Knife (stationary) | 1 |
| 3. Thread Unwinder spool cap | 5 |
| 4. Anti-spill net | 5 |
| 5. Oiler | 1 |
| 6. Allen Screw driver (small) | 1 |
| 7. Tweezers | 1 |
| 8. Needle set | 1 |
| 9. Brush | 1 |
| 10. Cone Adapters | 5 (on machine) |
| 11. Waste tray | 1 in carton |
| 12. Machine cover | 1 in carton |
| 13. Knife cover | 1 |

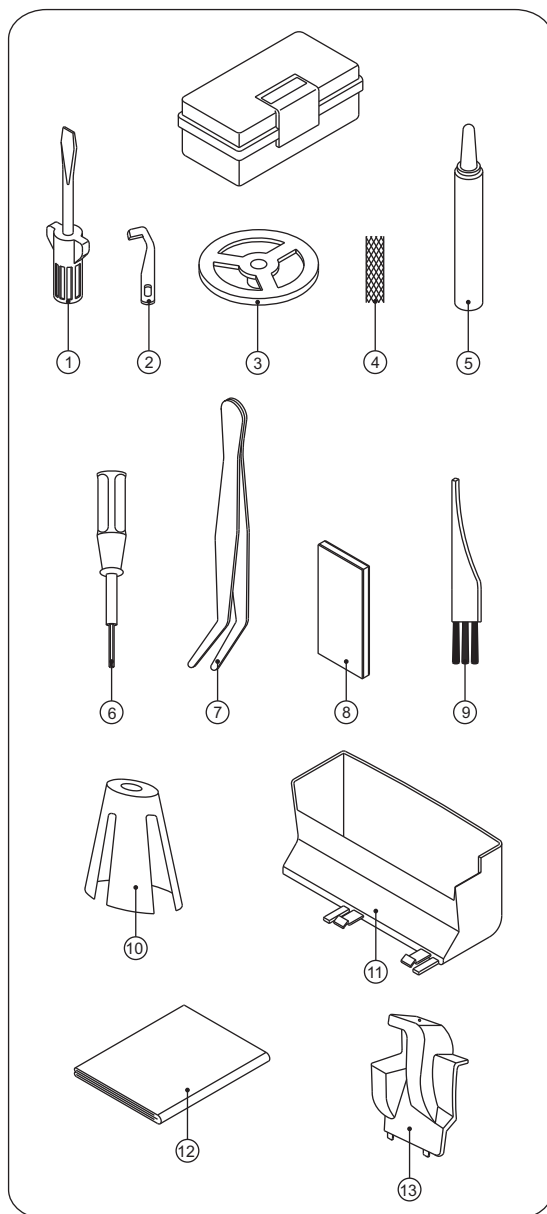

4. NEEDLE INFORMATION

- This overlock uses a flat shank industrial needle that eliminates the possibility of inserting the needle backwards.
- Do not attempt to use a standard household sewing machine needle of any size or type in this overlock.
- Singer needle #2022 size 14/90 is furnished with the machine.
- Only use Needle #2022 size 14/90 and 11/80 as supplied in the accessory case.

#2022
Overlock needle

5. PRINCIPAL PARTS

1. Thread guides and holder
2. Handle
3. Left needle thread tension fine tuning lever (orange)
4. Right needle thread tension fine tuning lever (blue)
5. Upper looper thread tension fine tuning lever (green)
6. Lower looper thread tension fine tuning lever (red)
7. Chain stitch looper thread tension fine tuning lever (brown)
8. Needle plate
9. Cloth plate
10. Looper cover
11. Power & light switch
12. Stitch length dial
13. Hand wheel
14. Spool stand
15. Cone adaptor
16. Spool pin
17. Waste tray
18. Auto tension dial
19. Seam guide plate

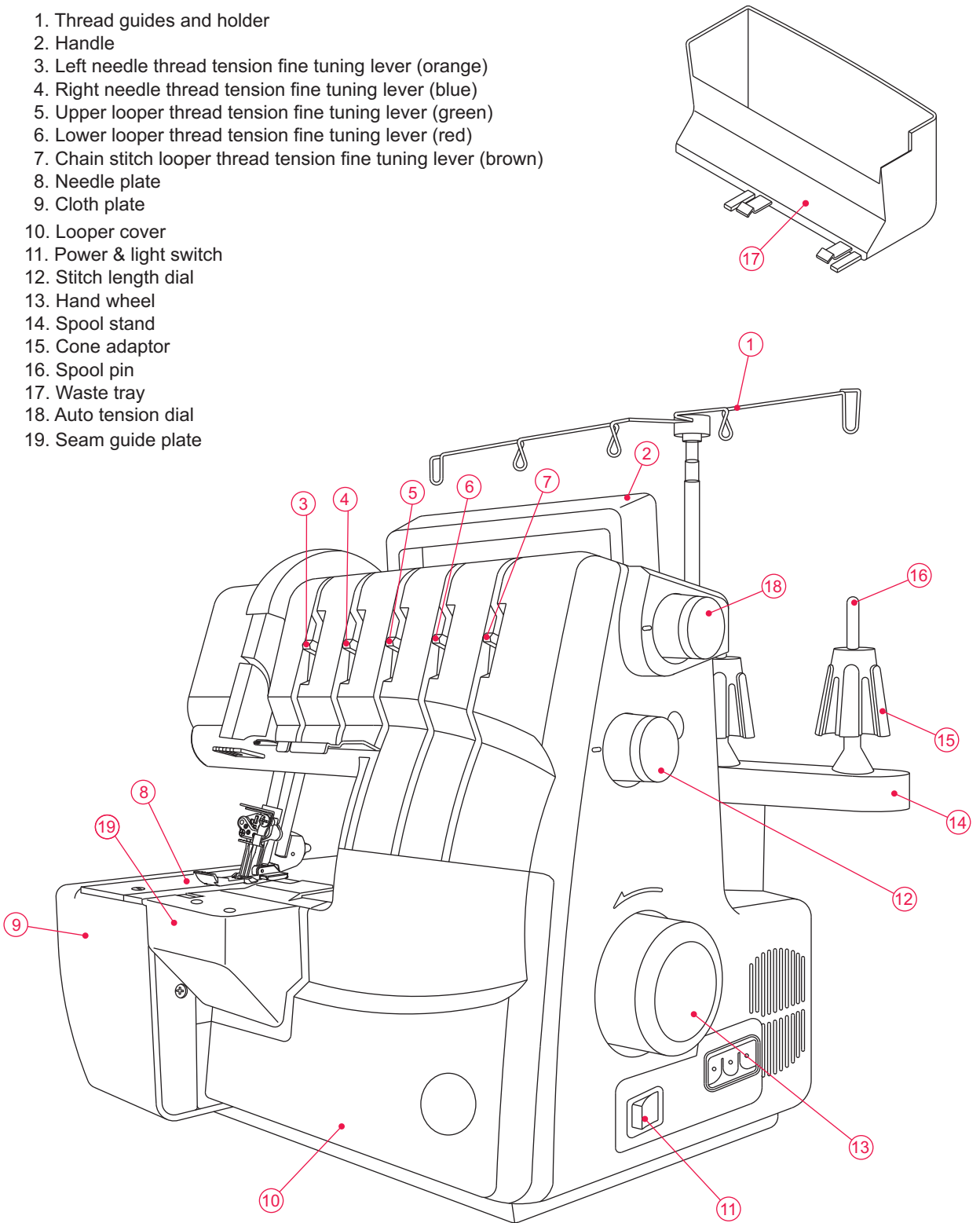

PRINCIPAL PARTS

- 20. Presser bar lifter and tension release
- 21. Differential feed adjusting dial
- 22. Cutting width dial
- 23. Presser foot pressure adjusting dial

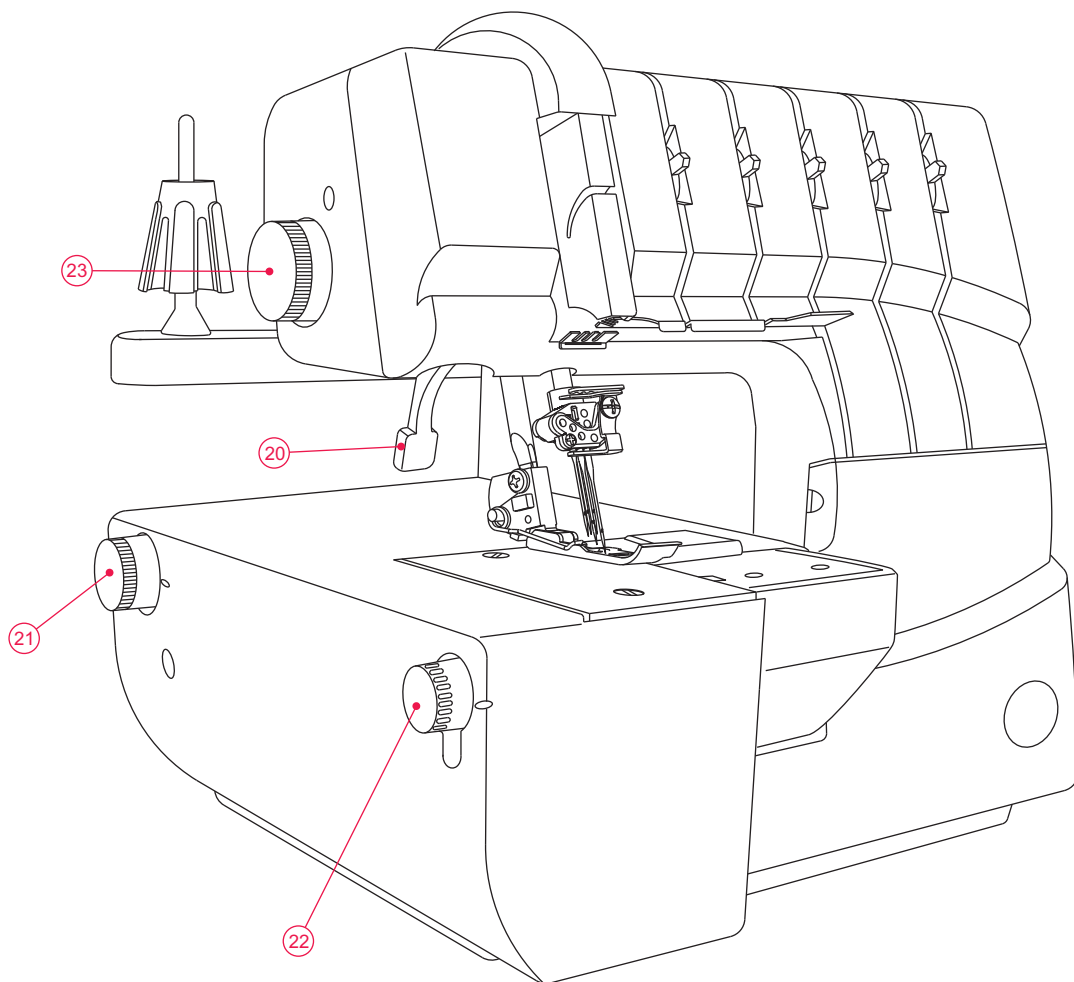

6. HOW TO OPEN LOOPER COVER



Caution:

Be sure to turn off power switch.

- Push the cover to the right as far as it will go.
- Pull cover down toward you.



Caution:

Be sure looper cover is closed when sewing.

Note: Machine will not operate when Looper Cover is open.

7. PRINCIPAL PARTS BEHIND THE LOOPER COVER

1. Upper looper
2. Moveable Upper knife
3. Presser foot
4. Fixed position lower knife
5. Lower looper
6. Chain/Cover looper
7. Rolled Hem lever
8. Spreader
9. Upper looper clutch

8. PREPARATION PRIOR TO SEWING

- Connect the controller/electric plug to the machine receptacle.
- Plug power line into electric outlet.
- Power Switch: Push "I" mark side to turn "ON"
Push "O" mark side to turn "OFF"
- To run the machine and control the speed, press the controller.
- The harder you press, the faster the machine will sew.
- To stop the machine from sewing, remove your foot from the controller.

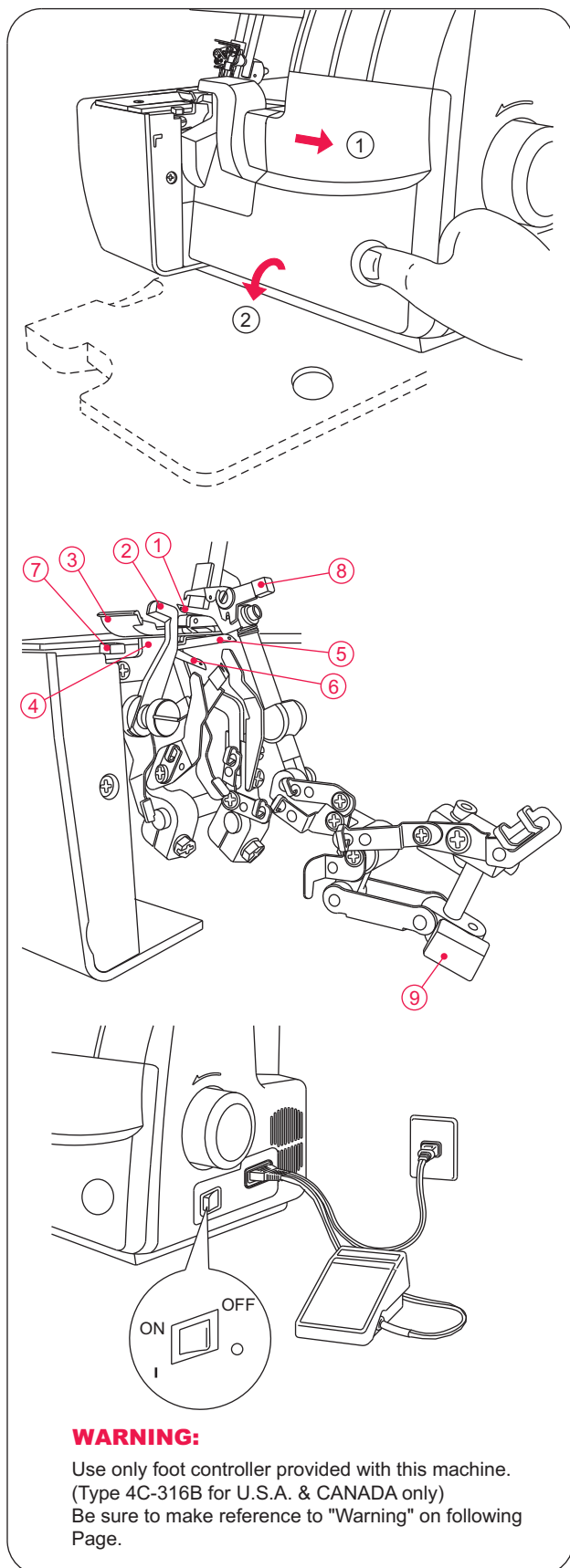

WARNING:

Use only foot controller provided with this machine.
(Type 4C-316B for U.S.A. & CANADA only)
Be sure to make reference to "Warning" on following Page.

POLARIZED PLUG INFORMATION (FOR U.S.A. & CANADA ONLY)

This appliance has a polarized plug (one blade wider than the other). To reduce the risk of electric shock, this plug is intended to fit in a polarized outlet only way. If the plug does not fit fully in the outlet, reverse the plug. If it still does not fit contact a qualified electrician to install the proper outlet. Do not modify the plug in any way.



Warning:

- * Be sure that the electrical voltage of the electric outlet (wall receptacle) is the same as the rated voltage of the motor.
- * Handle the foot controller with care and avoid dropping it on the floor. Be sure not to place anything on top of it when not in use.
- * Disconnect the power line plug from the electric outlet when changing needles, presser feet or when leaving the machine unattended. This eliminates the possibility of starting the machine by accidentally pressing the controller.

9. REMOVAL AND REPLACEMENT OF WASTE TRAY

Replacement

- Insert the waste tray under the looper cover.

Be sure the left side of waste tray is mounted near the cutter where the scraps drop.

Removal

- To remove, hold the waste tray as shown and pull it outward.

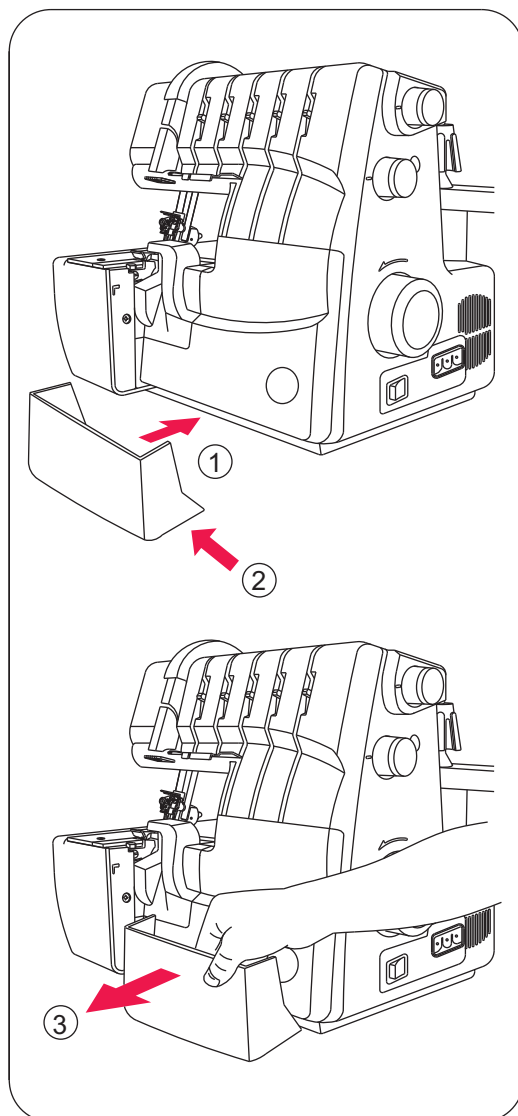

10. PREPARATION FOR THREADING

Setting Up the Thread Guide Holder

- Take out the thread guide from the top of Styrofoam, and insert it as shown on illustration.
- This machine is shipped with the thread guide holder in the lowered position.
- Fully extend the thread guide holder.
- The two joints on the telescope will click into place when they are correctly positioned.
- Center the thread guides above the spool pins.
- Place thread over the cone adapters on the spool pins.

Note: Your new machine is threaded to sew Triple Cover Stitch. Refer to Page 30 for instructions on tying on to the threads.

Anti-spill Net

- When using synthetic threads that easily spill off the cone, slip the anti-spill net furnished with the machine over the thread from the bottom of the cone leaving the thread end hanging free at the top of the anti-spill net as shown on illustration.

Spool Cap

- When using a regular thread spool, fit the spool cap supplied with the machine onto the thread spool as shown on illustration.

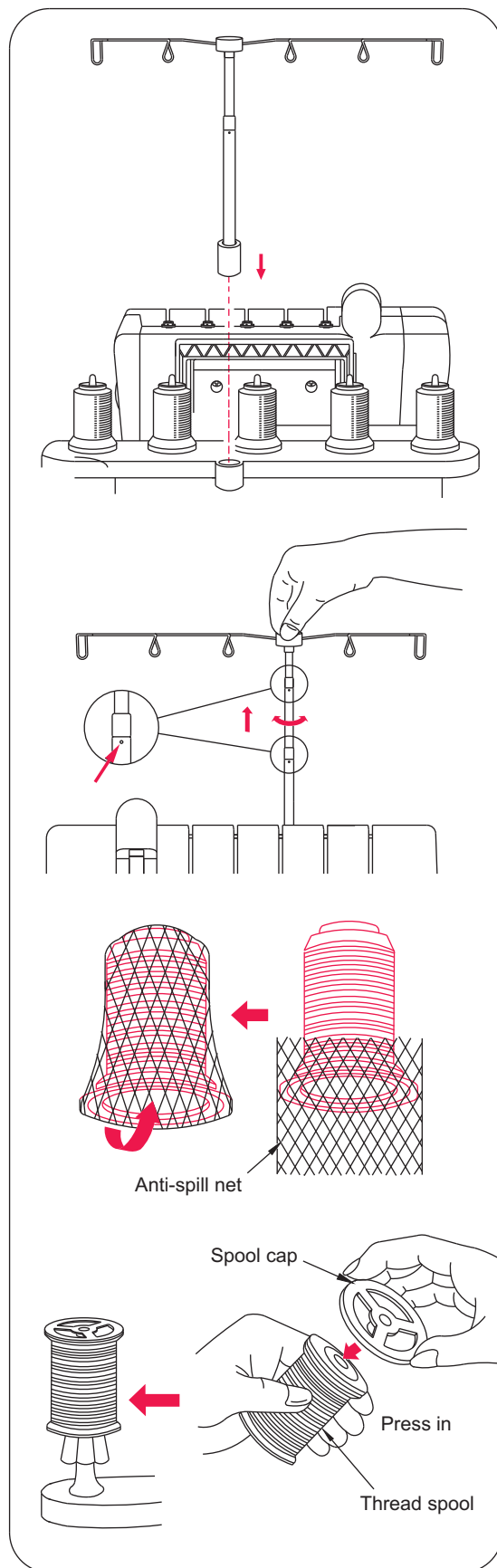

11. HOW TO REMOVE AND INSERT NEEDLES

Needle Position

- With this machine, five needles can be inserted into the needle clamp as shown in the drawing but only one or two or three needles are to be used for sewing. Do not attempt to use four or five needles.
- The Instruction Book refers to different needle positions by illustrating the needle clamp at right.

Note: When both the left and right overedge needles are inserted, the left needle will be slightly higher than the right.

When all cover stitch needles are inserted, the center needle will be slightly higher than the right needle and the left needle slightly higher than the center needle.

To Remove Needle (s)



Caution:

Be sure to disconnect the machine from the electric outlet before removing needle(s).

- Turn the hand wheel toward you until the needles are at their highest position.
- Place a thick piece of fabric [such as felt] under the presser foot. Lower the needles halfway into the fabric.
- Loosen, but do not remove the needle set screws with the small allen screwdriver. Hold the needles with your fingers and raise the needle bar. The needles will remain in the fabric.
 - A. Overedge left needle
 - B. Overedge right needle
 - C. Cover stitch left needle
 - D. Cover stitch middle needle
 - E. Cover stitch right needle

To Insert Needles (s)

- Hold the needle with the flat surface to the back.
- Insert the needle into the needle socket as far as it will go.
- When inserting a needle, if you first lower it down into the hole in the needle plate it will line up with the needle socket. Then direct it upwards

Note: When inserting needles into the A or B sockets it is necessary to loosen both A & B Allen Screws. After inserting the needles equally tighten both screws.

This machine uses Singer #2022 needles. Do not use Standard Household Needles.

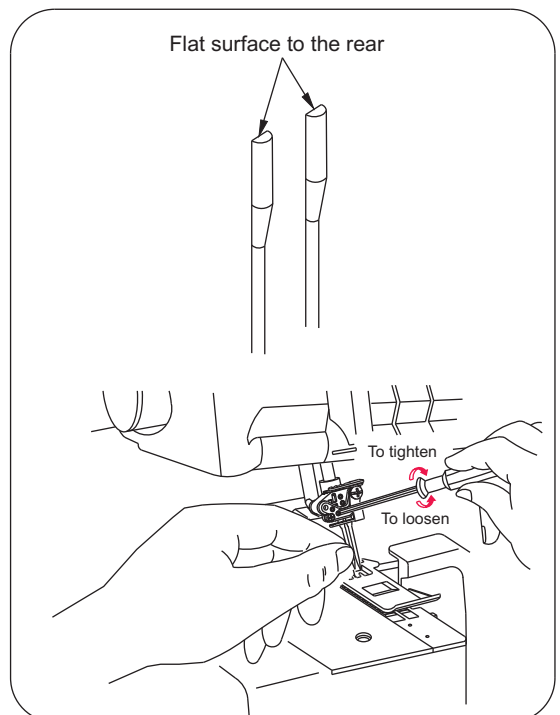
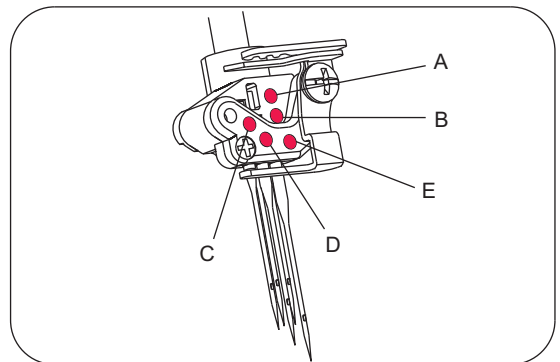
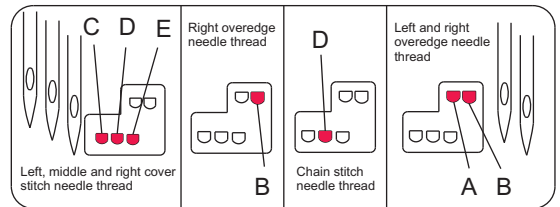
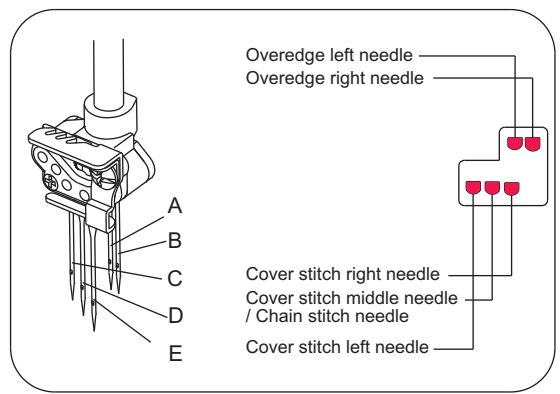

12. THREADING THE MACHINE

Threading Diagram: **Overlock and Safety Stitches**

- A color coded threading diagram is located inside the looper cover for quick reference.
- Thread the machine in the order 1 to 5 as shown.

Note: Threads go through the take-up lever cover for Overlock and Chain stitching as shown.

Tension Color Code: **Overlock and Safety Stitch**

1. Upper looper thread..... Green
2. Lower looper thread..... Red
3. Chain stitch looper thread..... Brown
4. Right needle thread..... Blue
5. Chain stitch needle thread..... Orange

Threading Diagram: **Cover Stitch**

- A color coded threading diagram is located inside the looper cover for quick reference.
- Thread the machine in the order 1 to 4 as shown.

Note: Threads go through take-up lever cover for Cover stitch as shown.

Tension Color Code: **Cover Stitch**

1. Cover stitch looper thread..... Brown
2. Right needle thread..... Green
3. Middle needle thread..... Blue
4. Left needle thread.....Orange

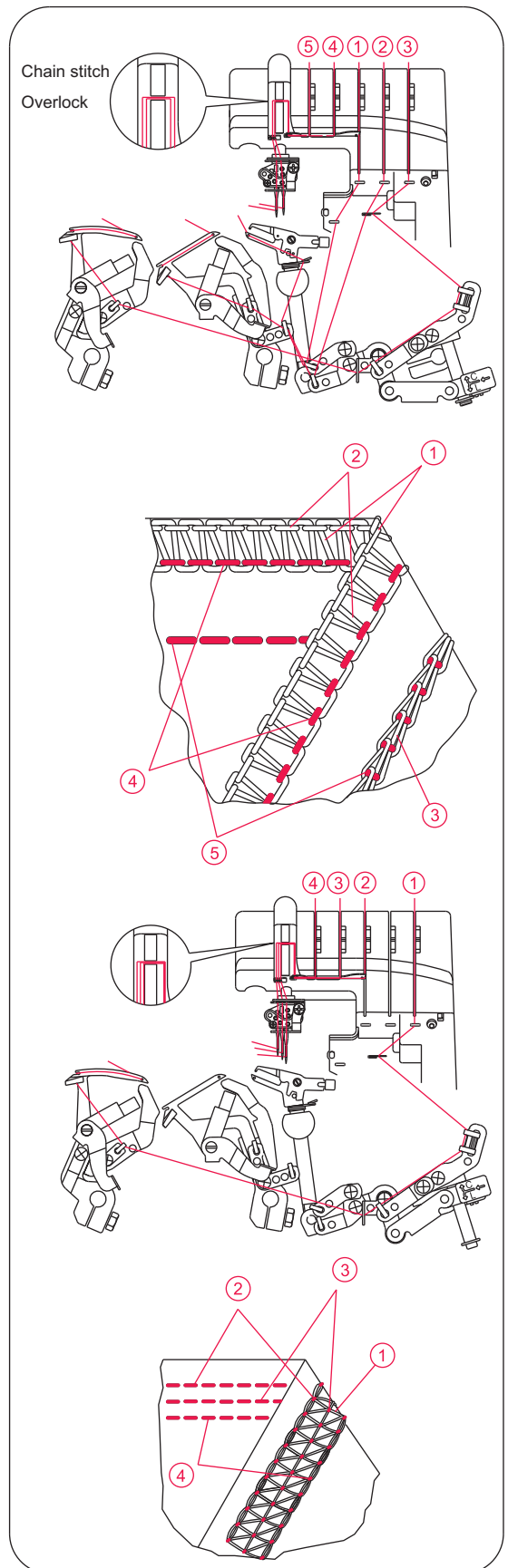

To Thread The Machine Correctly



Caution:

Be sure to turn off power switch.

Note: The instructions on this page and the following pages will guide you through the proper threading for each color coded threading path. Before threading, refer to the Handy Reference Chart for information on Stitch Types, Settings, Needle Sockets and Color Coded Threading Paths.

1) Threading the **Upper Looper** (Green)

- Thread the upper looper as indicated 1~9.
- Raise Presser foot to release tension discs.

Note: The presser foot is raised by lowering the Presser bar lifter. The motion allows a clear path for the fabric when sewing.

- Pass thread from back to the front through the thread guide 1.

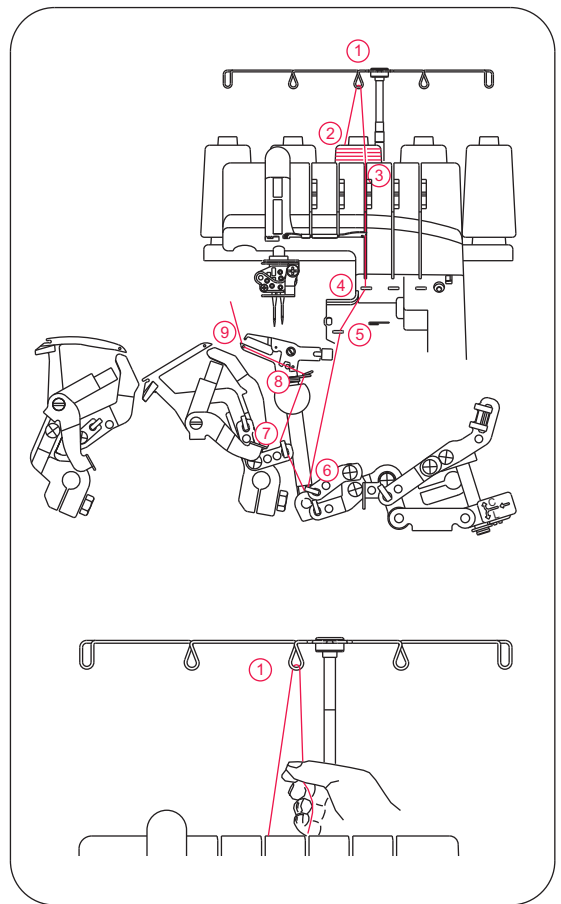

- Thread the top cover thread guide by pulling the thread towards the left until it slips under guide. Then pull thread along the right side of button as illustrated.

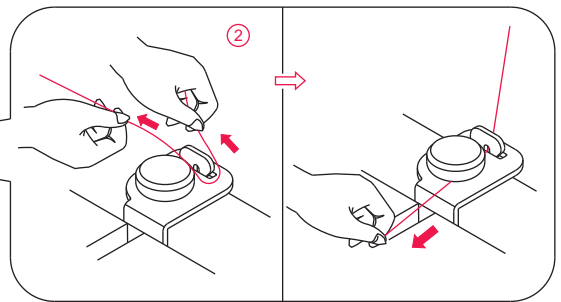
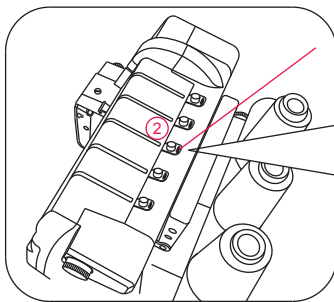

- While holding thread with fingers, pass it between the tension discs and pull thread down to make certain it is properly located in between the tension discs 3.

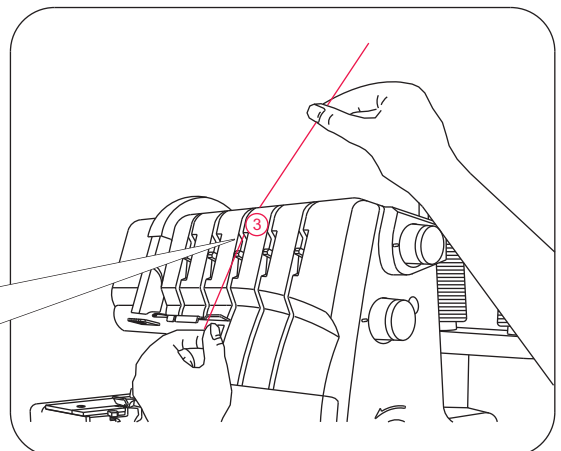
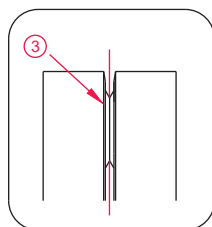

- Thread the looper area of the machine following the green color coded thread guides (4-9).
 - Thread the hole in the upper looper from front to back 9. Note: Make sure thread passes behind lower looper.
- Note: Use tweezers provided in the accessory case to aid in threading the looper.
- Pull about 10cm(4 inches) of thread through the looper and place to the back of the needle plate.

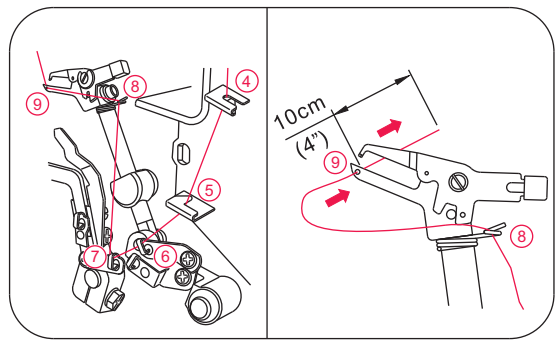

2) Threading the Lower Looper (Red)

- Thread the lower looper as indicated 1-10.
- Raise Presser foot by lowering presser bar lifter to release Tension discs.
- Pass thread from back to the front through the thread guide 1.

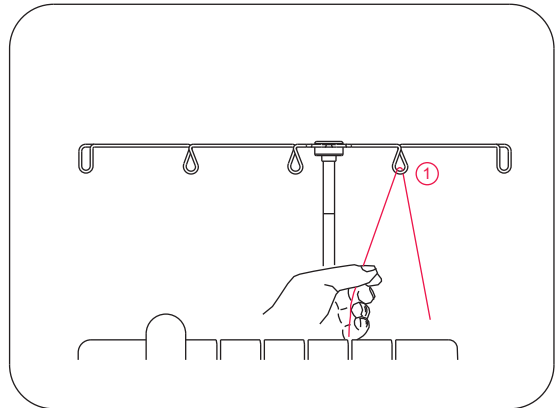
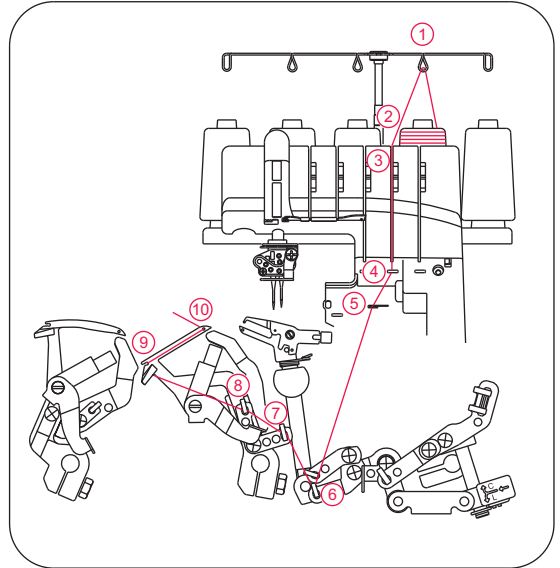

- Thread the top cover thread guide by pulling the thread towards the left until it slips under guide. Then pull thread along the right side of button as illustrated.

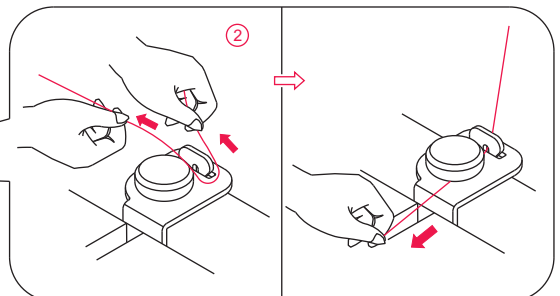
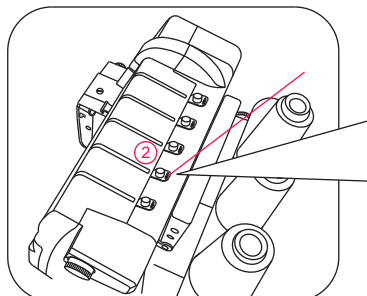

- While holding thread with finger, pass it between the tension discs and pull thread down to make certain it is properly located in between the tension discs 3.

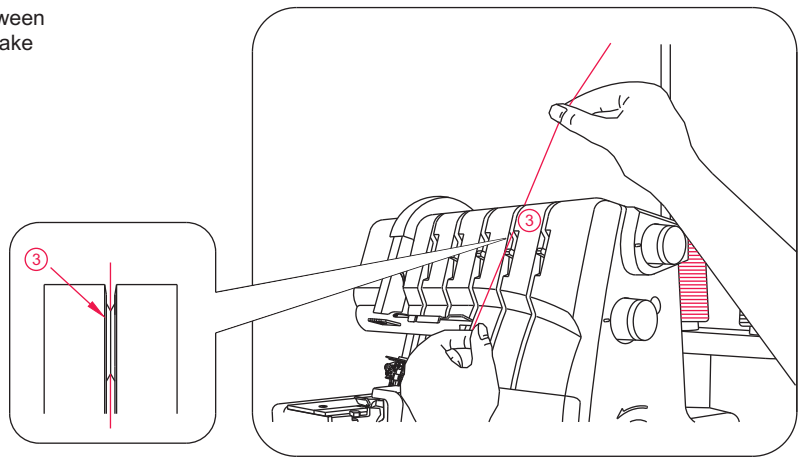

- Turn the hand wheel toward you until the lower looper extends out 5~10mm from the needle plate edge.
- Thread the looper area of the machine following the red color coded thread guides 4~10.

Note: Use tweezers provided in the accessory case to aid in threading the looper.

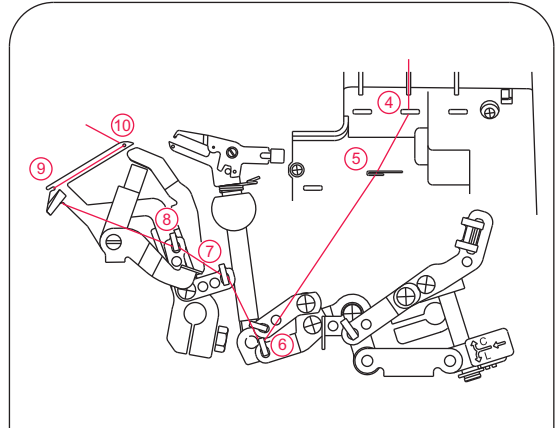

- Place the thread with the point of the tweezers slightly from left and to the right of threading guide 4.

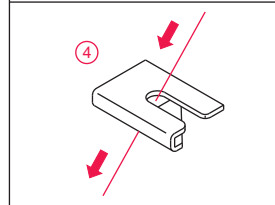

- Place the thread with the point of the tweezers slightly from front and to the back of threading guide 5.

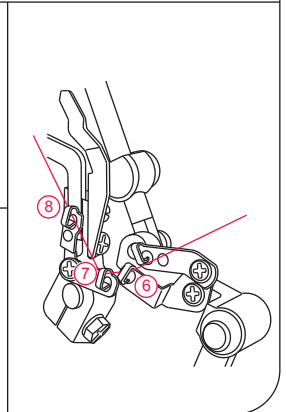
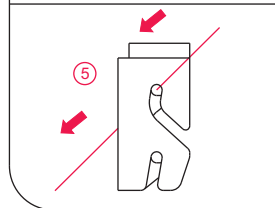

- Thread the looper eye (A) from front to back. Pull about 10cm (4 inches) of thread. Position thread into V cutout (B) on threader. Firmly hold thread tail with left hand and pull Threader lever (C) up into place (D).

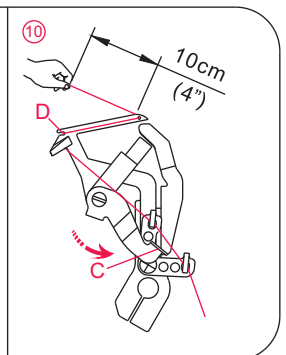
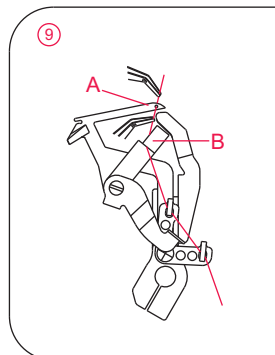

3) Threading the **Chain Stitch/Cover stitch Looper (Brown)**

- Thread the chain stitch/cover stitch looper as indicated 1~11.

- Raise Presser foot by lowering presser bar lifter to release Tension discs.

- Pass thread from back to the front through the thread guide 1.

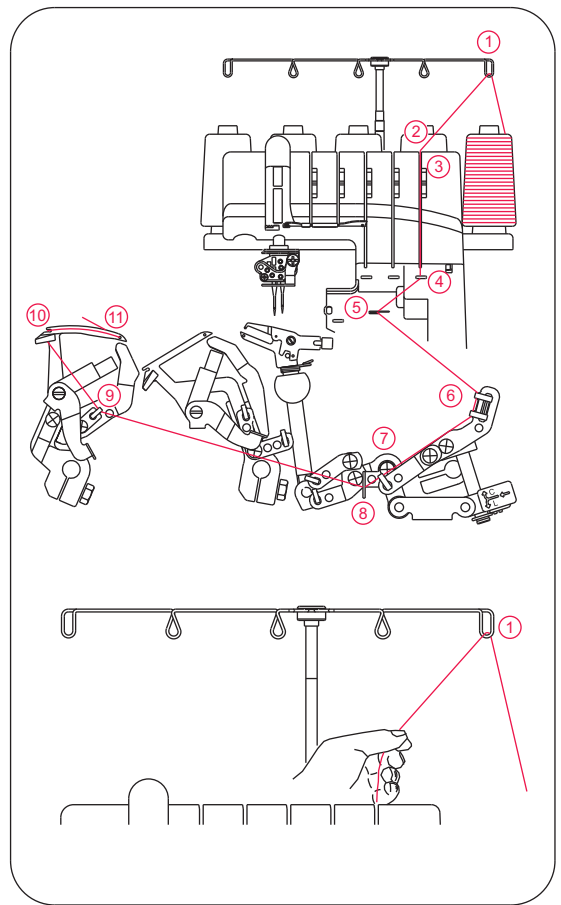

- Thread the top cover thread guide by pulling the thread towards the left until it slips under guide. Then pull thread along the right side of button as illustrated.

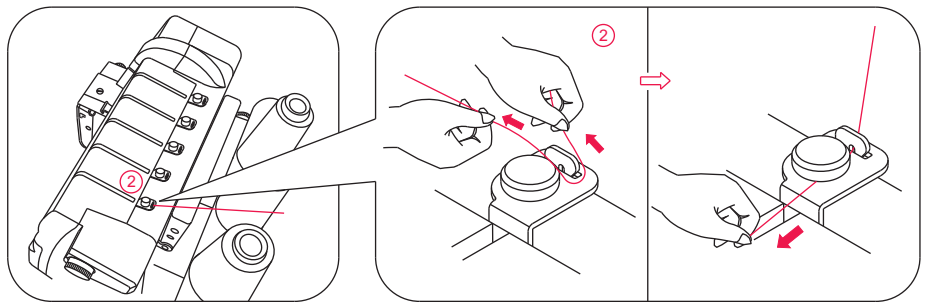

- While holding thread with fingers, pass it between the tension discs and pull thread down to make certain it is properly located in between the tension discs 3.

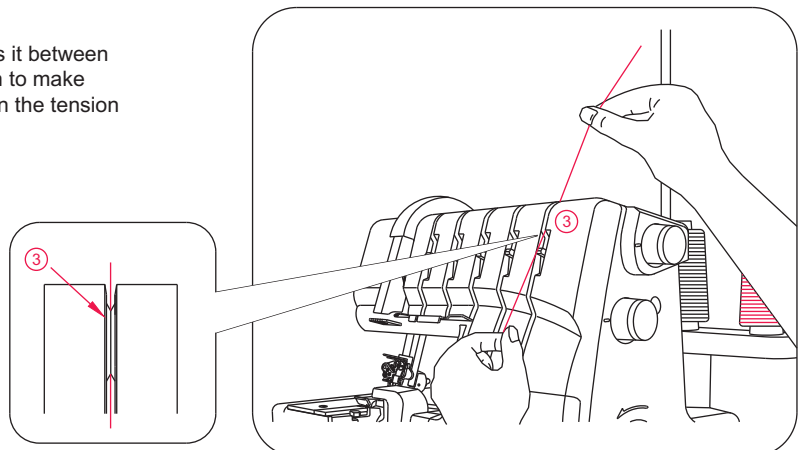

- Turn the hand wheel toward you until the chain stitch looper extends out 10mm from the needle plate edge.
- Thread the looper area of the machine following the brown color-coded thread guides 4~11.

Note: Use the tweezers provided in the accessory case to aid in threading the looper.

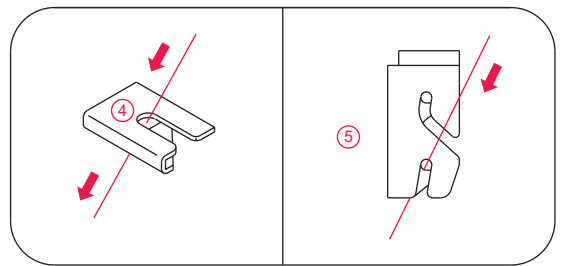

- Place the thread with the point of the tweezers through threading guide 4.
- Place the thread with the point of the tweezers through the front slot of threading guide 5.

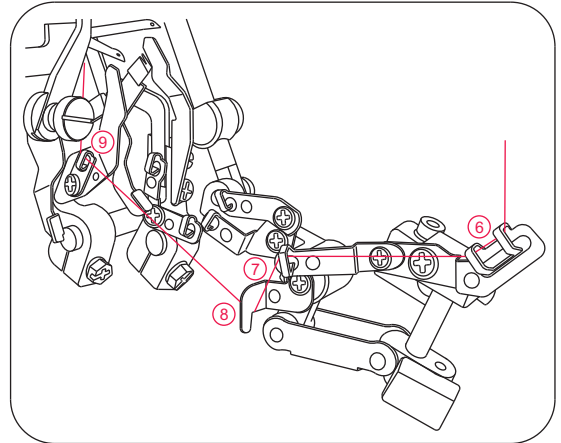

- Thread the looper eye (A) from front to back. Pull about 10cm (4 inches) of thread through the looper. Position thread into V cutout (B) on threader. Firmly hold thread tail with left hand and pull threader lever (C) up into place (D).

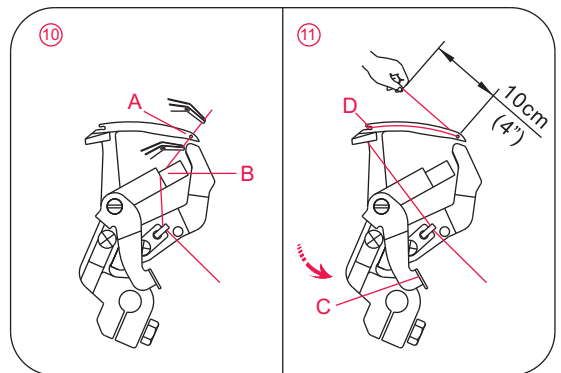

4) Threading the **Overedge Right Needle (Blue)** (B on needle clamp)

- Thread the right needle as indicated 1~9.
- Raise Presser foot by lowering presser bar lifter to release Tension discs.

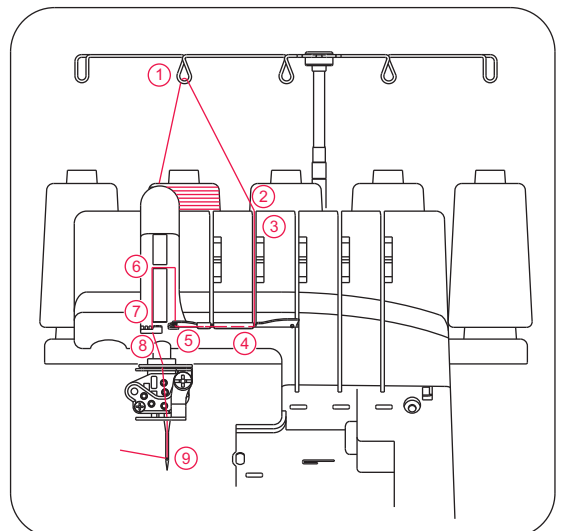

- Pass thread from back to the front through the thread guide 1.

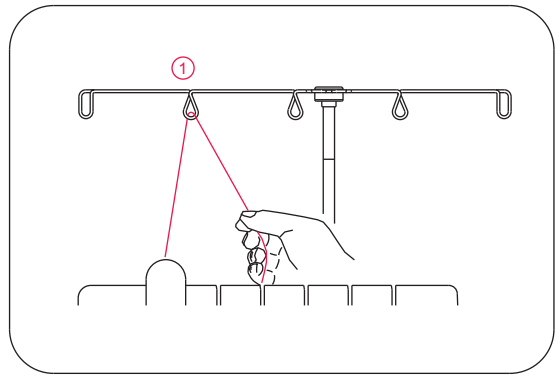

- Thread the top cover thread guide by pulling the thread towards the left until it slips under guide. Then pull thread along the right side of button as illustrated.

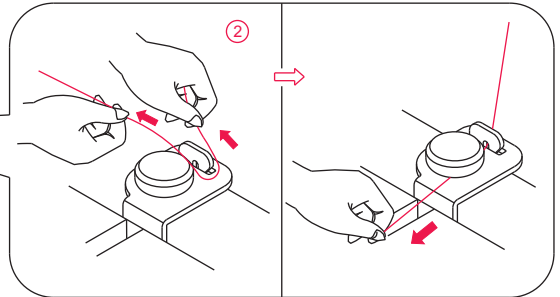
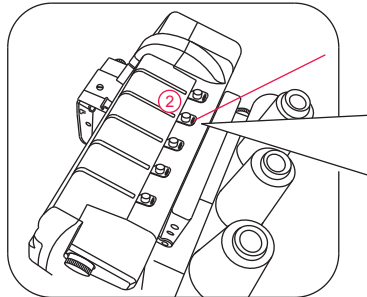

- While holding thread with finger, pass it between the tension discs and pull thread down to make certain it is properly located in between the tension discs 3.

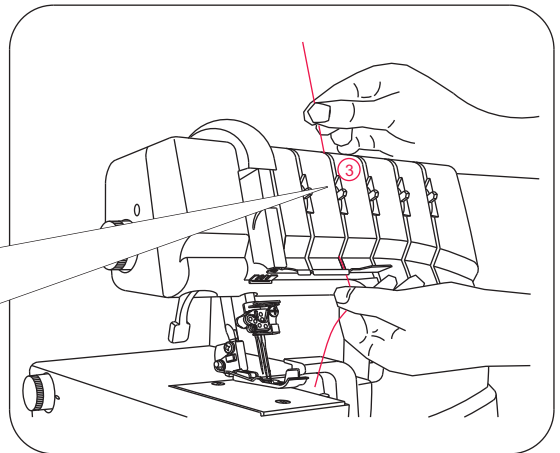
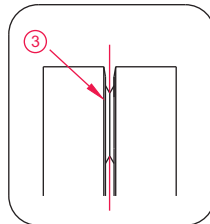

- Continue to thread points 4~8.

Note: Slip thread into the rear slot on the thread guide 5 and the slot of take-up lever cover 6. Then slip thread into the right slot on the thread guide 7, and into the right slot on the thread guide 8.

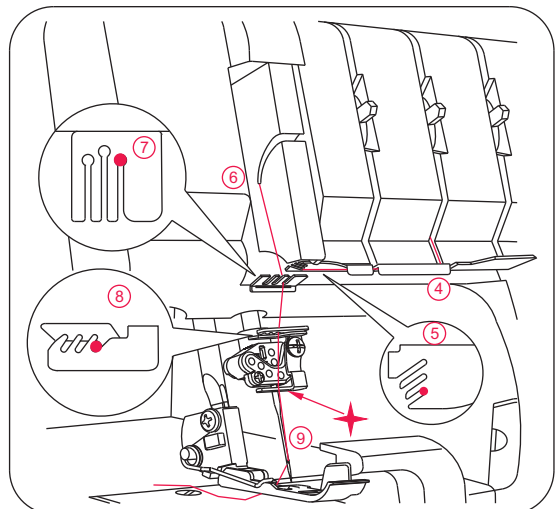

- ★ Before threading eye of needle, slip thread behind thread guide located on the bottom of the needle clamp.

- Thread the eye of the right needle 9.

Note: Use of tweezers in the accessory case will make needle eye threading easy.

- The position of the thread must be behind the thread guide.
- Draw about 10cm(4 inches) of thread through needle eye towards the rear of machine.
- Place the thread to the back, under the presser foot.

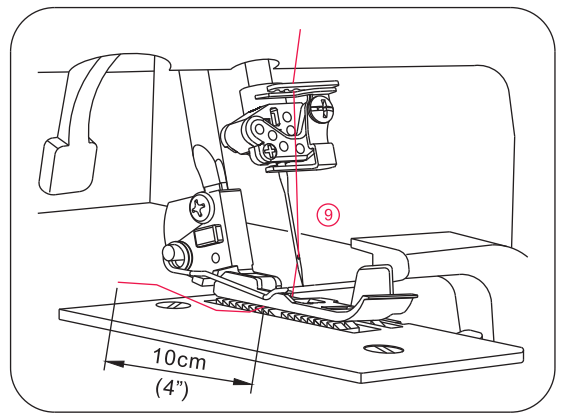

5) Threading the Chain Stitch Needle (Orange) (D on needle clamp)

- Thread the left needle as indicated 1-9.
- Raise Presser foot by lowering presser bar lifter to release Tension discs.

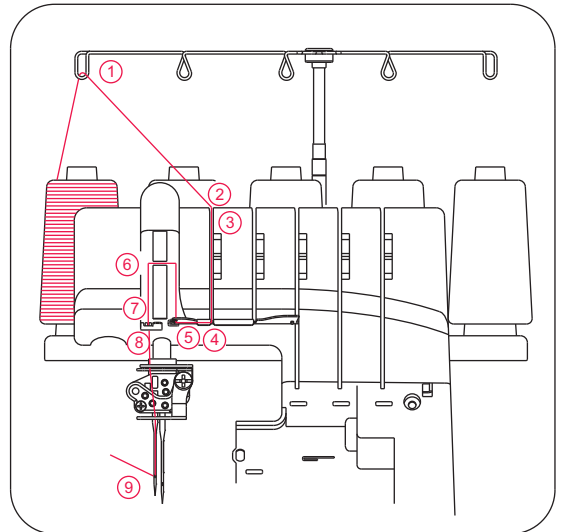

- Pass thread from back to the front through the thread guide 1.

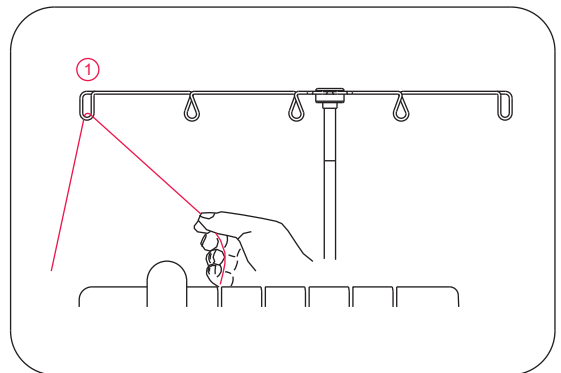

- Thread the top cover Thread guide by pulling the thread towards the left until it slips under guide. Then pull thread along the right side of button as illustrated.

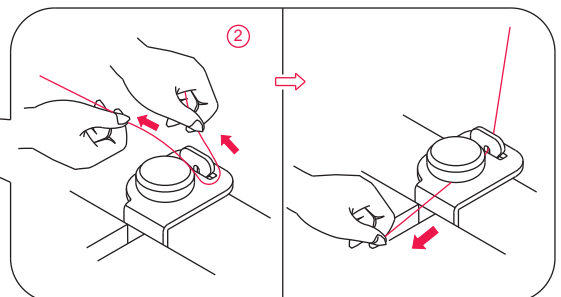
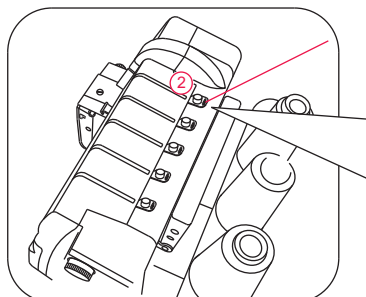

- While holding thread with fingers, pass it between the tension discs and pull thread down to make certain it is properly located in between the tension discs 3.

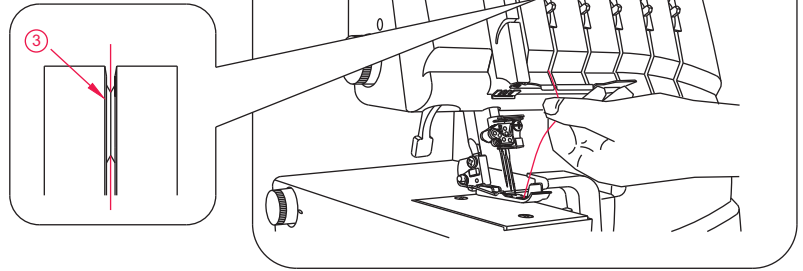

- Continue to thread points 4-8.

Note: Slip thread into the middle slot of the thread guide 5 and into the slot of take-up lever cover 6.

Then continue by slipping thread into the middle slot of the thread guides 7 and 8.

Note: For 4 thread overlock left needle: Use needle A.

Before threading eye of needle, slip thread behind thread guide located on the bottom of the needle clamp.

Note: For chain stitch :Use needle D.

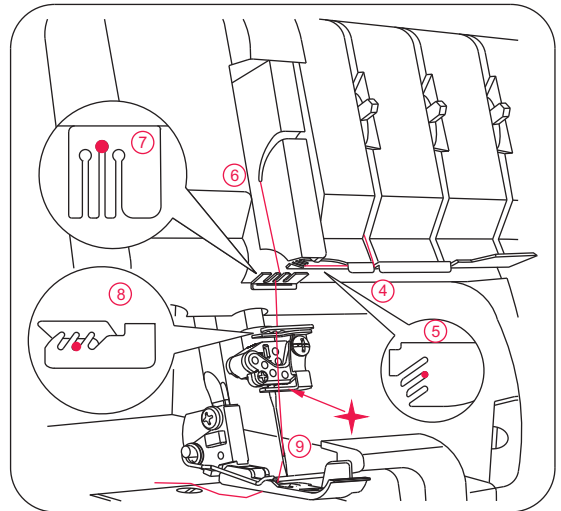

✦ Before threading eye of needle, make sure thread is **in front of thread guide** located on the bottom of the needle clamp.

- Thread the eye of the left needle 9.

Note: Use of tweezers in the accessory case will make needle eye threading easy.

- The position of the thread must be behind the the thread guide.
- Draw about 10cm (4 inches) of thread through needle eye to hang free.
- Place the thread to the back, under the presser foot.

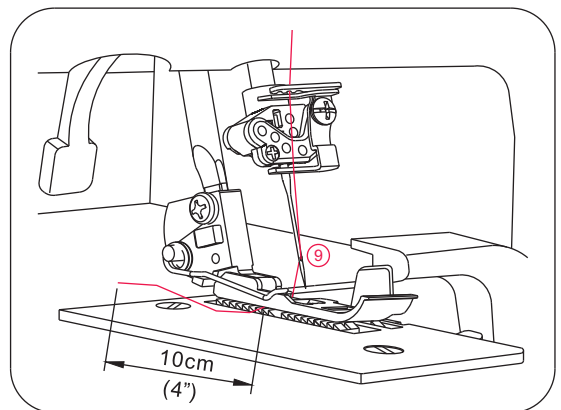

6) Threading the Cover Stitch Needles

(1) Threading the Cover Stitch Left Needle (Orange) (C on needle clamp)

- Thread the cover stitch left / chain stitch needle as indicated 1-9.
- Raise Presser foot by lowering presser bar lifter to release Tension discs.

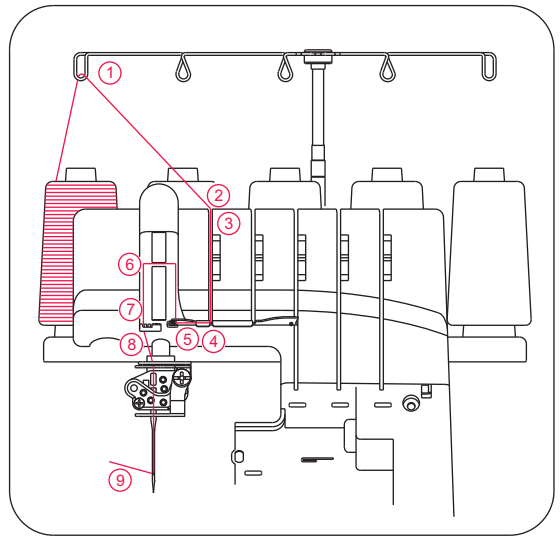

- Pass thread from back to the front through the thread guide 1.

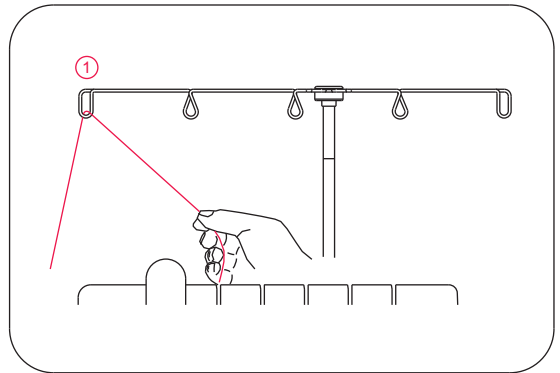

- Thread the top cover thread guide by pulling the thread towards the left until it slips under guide. Then pull thread along the right side of button as illustrated.

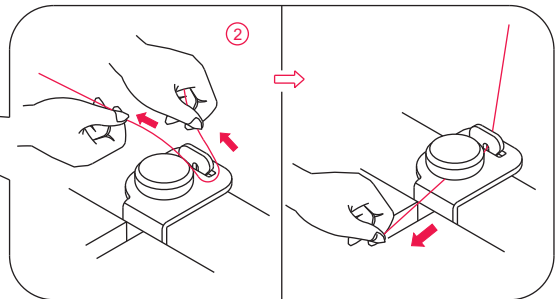
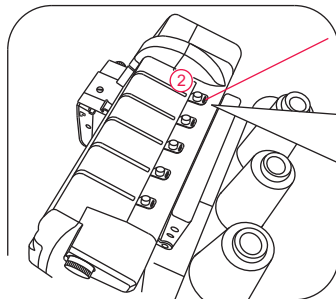

- While holding thread with finger, pass it between the tension discs and pull thread down to make certain it is properly located in between the tension discs 3.

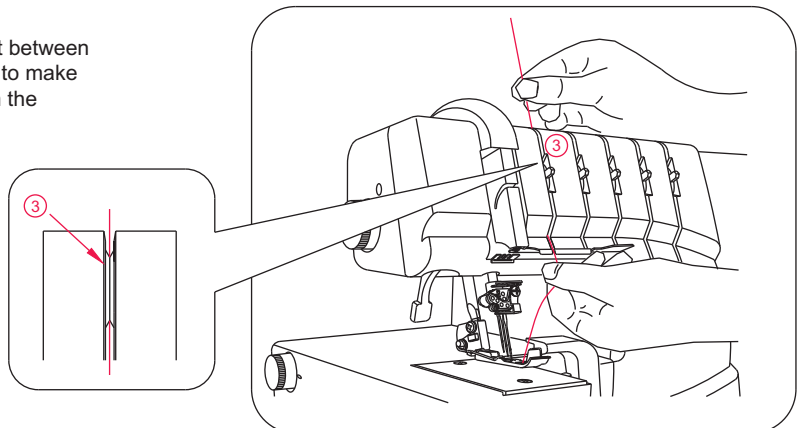

- Continue to thread points 4~8.

Note: Slide thread into front slot on thread guide 5 and slot of take-up lever cover 6. Then slip thread into left slots of thread guides 7 and 8.

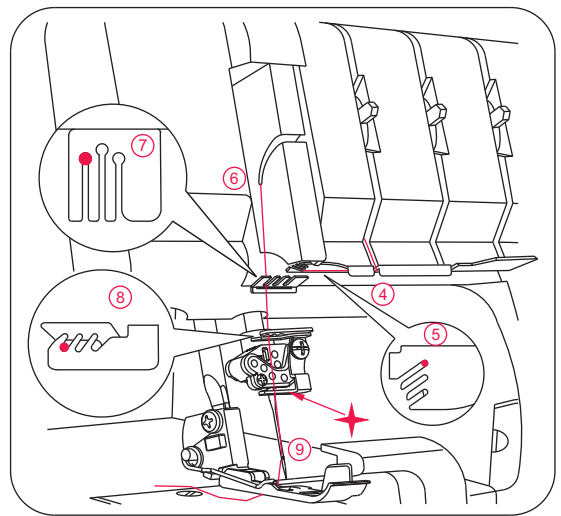

- ✦ Before threading eye of needle, make sure thread is **in front of thread guide** located on the bottom of the needle clamp.

- Thread the eye of the left needle 9.

Note: Use of tweezers in the accessory case will make needle eye threading easy.

- Draw about 10cm (4 inches) of thread through needle eye to hang free.
- Place the thread to the back, under the presser foot.

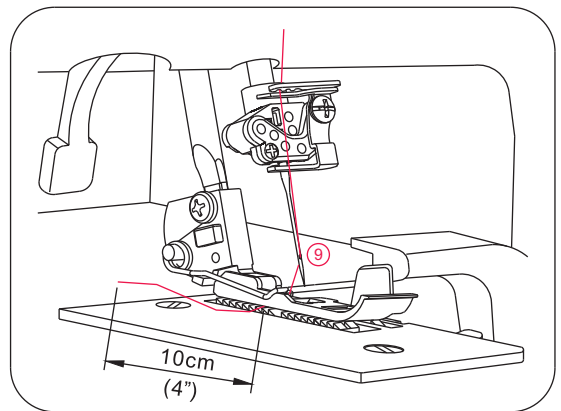

(2) Threading the **Cover Stitch Middle / Chain Stitch Needle** (Blue) (D on needle clamp)

- Thread the cover stitch middle / chain stitch needle as indicated 1~9.
- Raise the Presser foot by lowering presser bar lifter to release Tension discs.

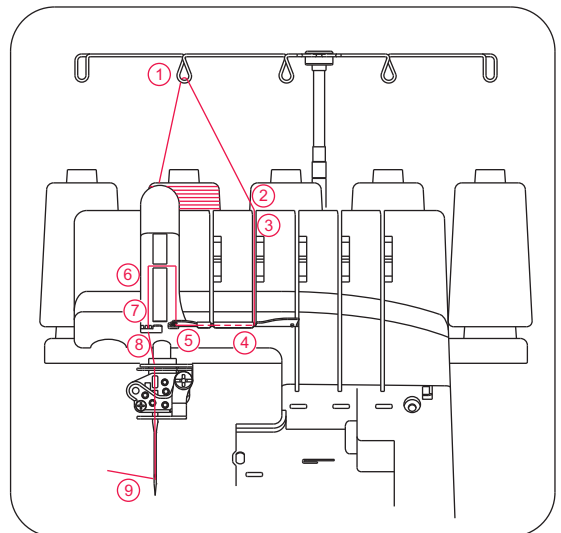

- Pass thread from back to the front through the thread guide 1.

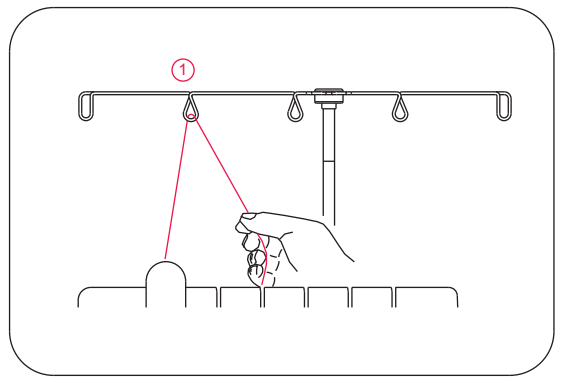

- Thread the top cover thread guide by pulling the thread towards the left until it slips under guide. Then pull thread along the right side of button as illustrated.

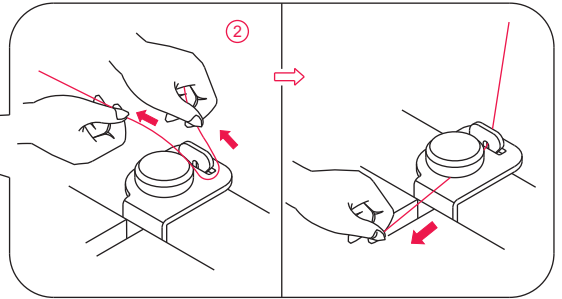
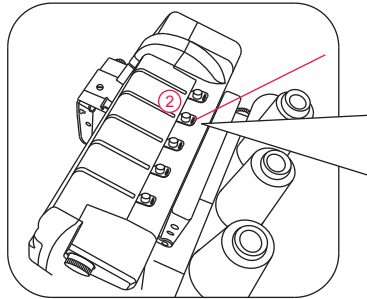

- While holding thread with fingers, pass it between the tension discs and pull thread down to make certain it is properly located in between the tension discs 3.

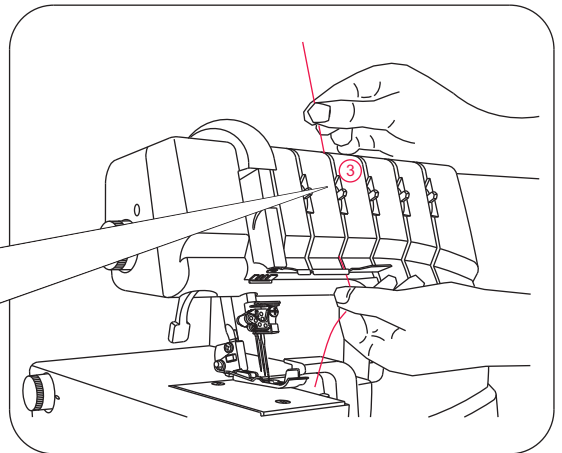
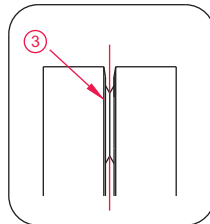

- Continue to thread points 4-8.

Note: Slip thread into the middle slot of the thread guide 5 and into the slot of take-up lever cover 6.

Then continue by slipping thread into the middle slot of the thread guides 7 and 8.

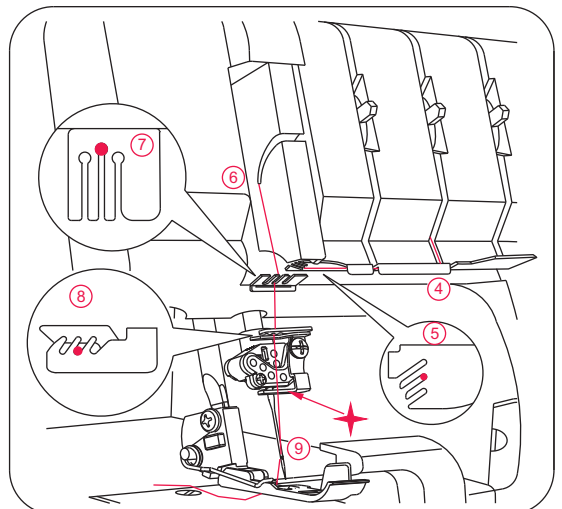

- ✦ Before threading eye of needle, make sure thread is **in front of thread guide** located on the bottom of the needle clamp for Cover stitch and for Chain stitch.

- Thread the eye of the middle needle 9.

Note: Use of tweezers in the accessory case will make needle eye threading easy.

- Draw about 10cm (4 inches) of thread through needle eye towards the back of the machine.
- Place the thread to the back, under the presser foot.

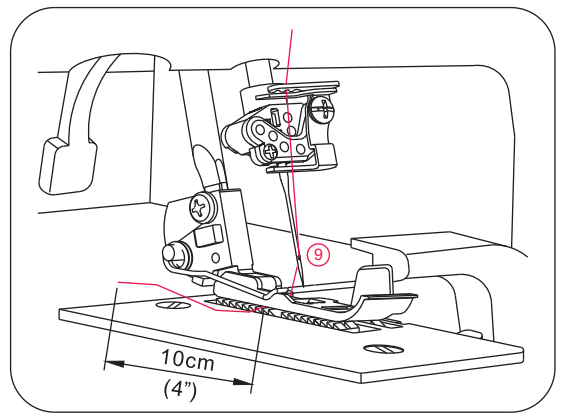

(3) Threading the Cover Stitch Right Needle (Green) (E on needle clamp)

- Thread the cover stitch right needle as indicated 1-9.
- Raise Presser foot by lowering presser bar lifter to release Tension discs.

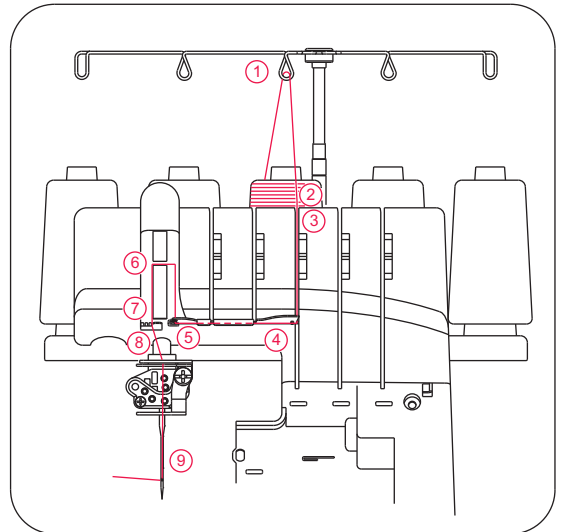

- Pass thread from back to the front through the thread guide 1.

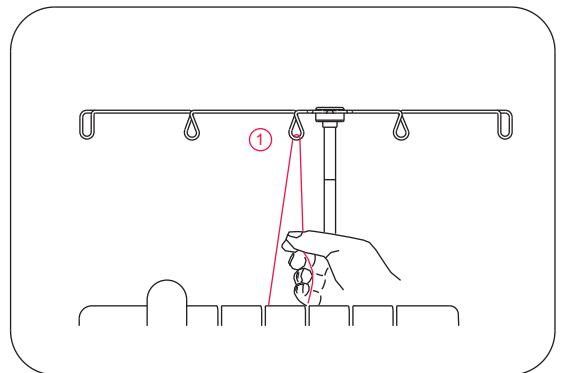

- Thread the top cover thread guide by pulling the thread towards the left until it slips under guide. Then pull thread along the right side of button as illustrated.

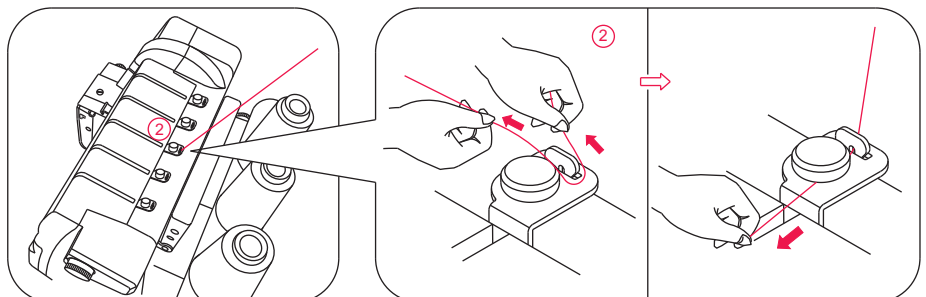

- While holding thread with fingers, pass it between the tension discs and pull thread down to make certain it is properly located in between the tension discs 3.

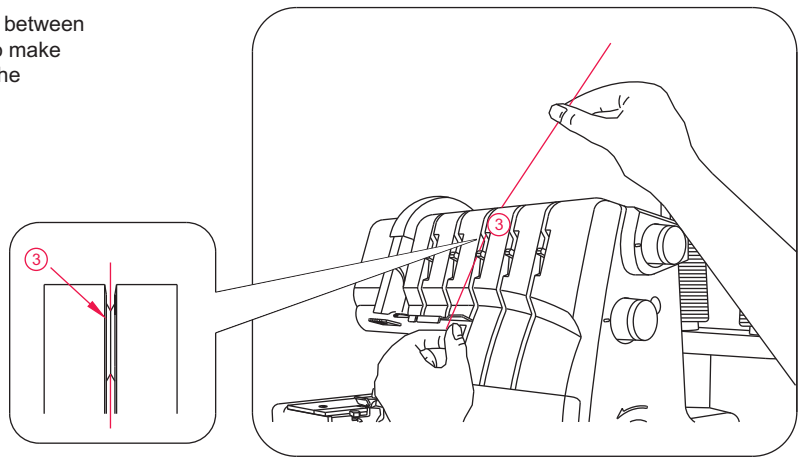

- Continue to thread points 4~8.

Note: Slip thread into the rear slot on thread guides 5. Slip the thread into the slot of the Take-up Lever Cover 6. Slip the thread into the right slots for thread guides 7 and 8.

- ✦ Before threading eye of needle 9, make sure thread is in front of thread guide located on the bottom of the needle clamp for Cover stitch.

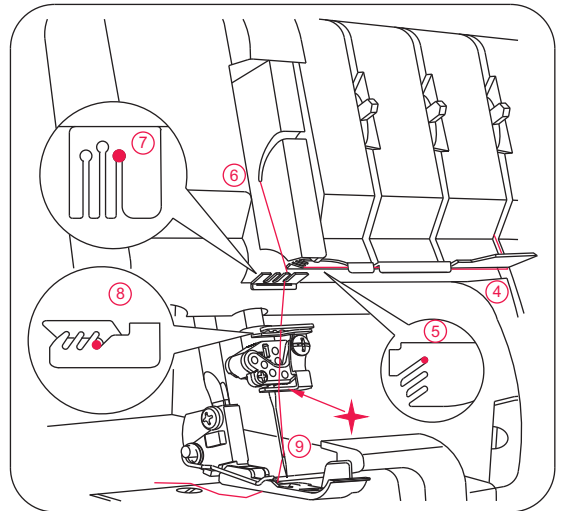

- Thread the eye of the right needle 9.

Note: Use of tweezers in the accessory case will make needle eye threading easy.

- Draw about 10cm (4 inches) of thread through needle eye towards the rear of the machine.
- Place the thread to the back under the presser foot.

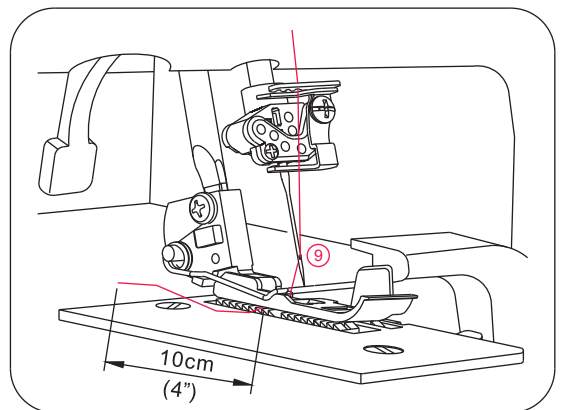

13. HOW TO CHANGE THREADS: TIE ON METHOD

- To change thread type or color, clip thread near the spool.

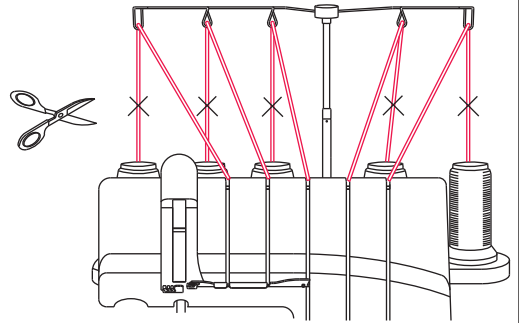

- Place new thread on stand.
- Tie new thread and old thread ends together with a square knot. Clip thread tails to 2~3cm (1 inch) length. If clipped too short, threads may come untied.
- Firmly pull both thread to test knot security.

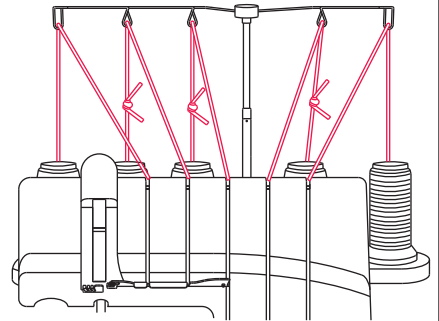

- Raise Presser foot by lowering presser bar lifter to release Tension discs.

- Pull the threads through the machine one at a time.
- If threads do not pull easily, check for tangles on thread guides or looping under thread stand.
- When pulling thread through the needles, **STOP** when the knot is in front of the needle.
- Cut the thread, and insert it through the needle.

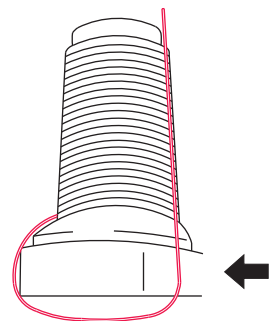

14. HOW TO ADJUST THE STITCH LENGTH

- The stitch length dial should be set on the N setting for most sewing conditions.
- Adjust the stitch length to N- 4 when sewing heavy weight fabrics.
- Adjust the stitch length to 2-N when sewing lightweight fabrics to obtain excellent seams without puckering.

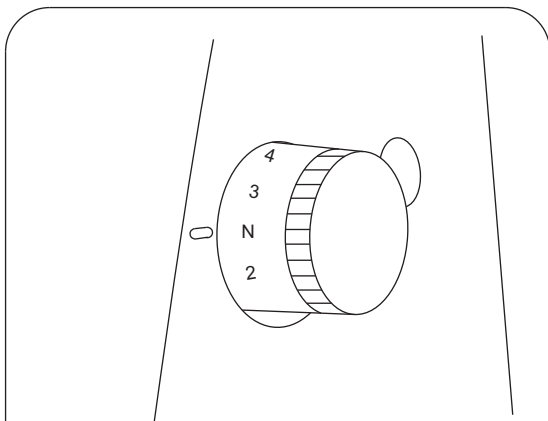

15. HOW TO ADJUST THE SEAM WIDTH

- Overedge seam width can be achieved by repositioning the needle position and also with the width adjustment knob.

Width Adjustment by Changing Needle Position

- Overedge seam width can be adjusted by changing the needle position.

- When using left needle.....6 mm
(15/64 inch)
- When only right needle is used.....4 mm
(10/64 inch)
- When using chain stitch needle.....8.8 mm
(11/32 inch)

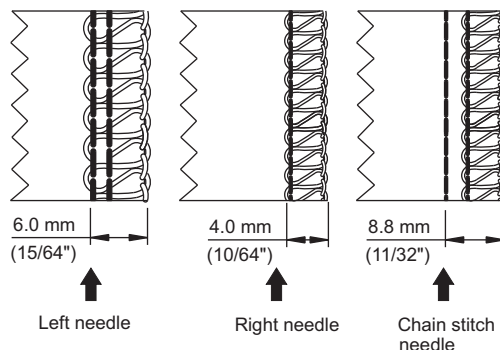

Width Adjustment with Adjustment Knob

- Use of width adjustment knob will permit further adjustment within the width range shown below.

- When using left needle.....5 ~ 7 mm
(13/64 ~ 17/64 inch)
- When only right needle is used.....3.0 ~ 5.0 mm
(1/8 ~ 3/16 inch)
- When using chain stitch needle.....7.8 ~ 9.8 mm
(5/16 ~ 3/8 inch)

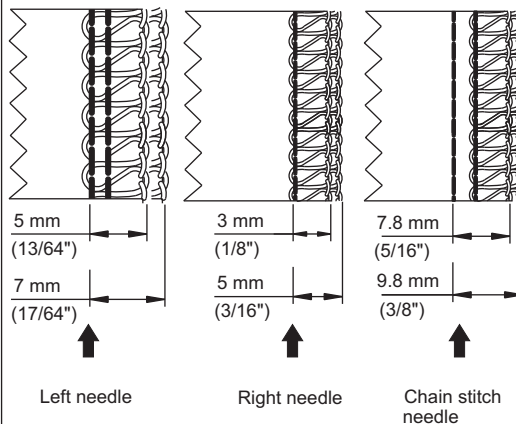

Width adjustment knob

As shown on the illustration, turn the dial counter clockwise to increase width of cutting, and clockwise to decrease width of cutting.

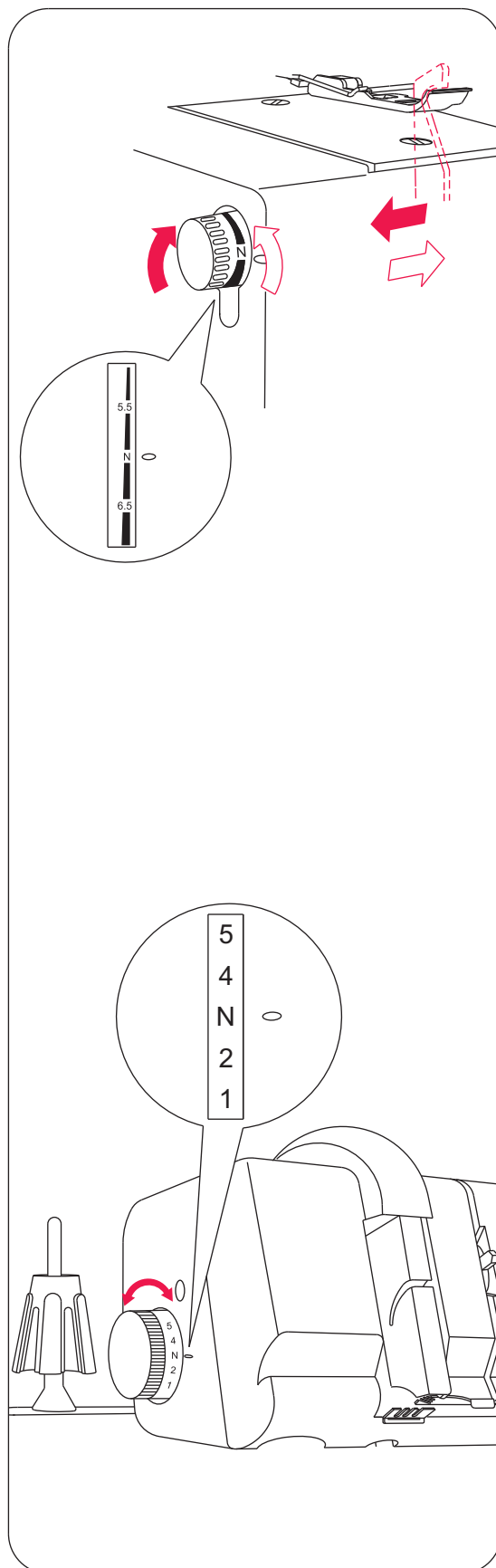

16. HOW TO ADJUST THE PRESSER FOOT PRESSURE

- The presser foot pressure of this machine is pre-adjusted at the factory to suit the sewing of medium weight fabrics.
- Most of the materials do not require adjustment of presser foot pressure. However, there are some instances where adjustment is necessary, such as when sewing lightweight and heavyweight fabrics.
- In such case, N for normal, 1 for the lightest pressure, and 5 for the heaviest.
- For lightweight fabric...Decrease the pressure
- For heavyweight fabric...Increase the pressure

17. DIFFERENTIAL FEED

- Differential feed is a system which "stretches" or "gathers" the fabric, when the amount of feed of front feed dogs in relation to the rear feed dogs is changed.
- The differential feed ratio ranges from 1:0.6~1:2.0. Adjustment is made by means of the differential feed adjusting dial pictured at right.
- Use of differential feed is very effective in overedging stretch fabrics and fabrics cut on the bias.
- Setting "N" is differential feed adjusting dial setting for ratio 1:1.

Gathered Overedge

- Gathered overedge is most suited for shirring sleeves, yokes, front and back bodices, skirt hems, etc. in stretch fabrics such as knits and jersey before assembling into garment.

To set the differential feed adjusting dial for gathering

- Set differential feed adjusting dial below setting "N". Setting of adjusting dial depends on material being sewn as well as the amount of desired gather. Therefore, set dial to suit the fabric and test sew before sewing your garment.

Note: For normal overedge stitching, set differential feed adjusting dial to graduation "N".

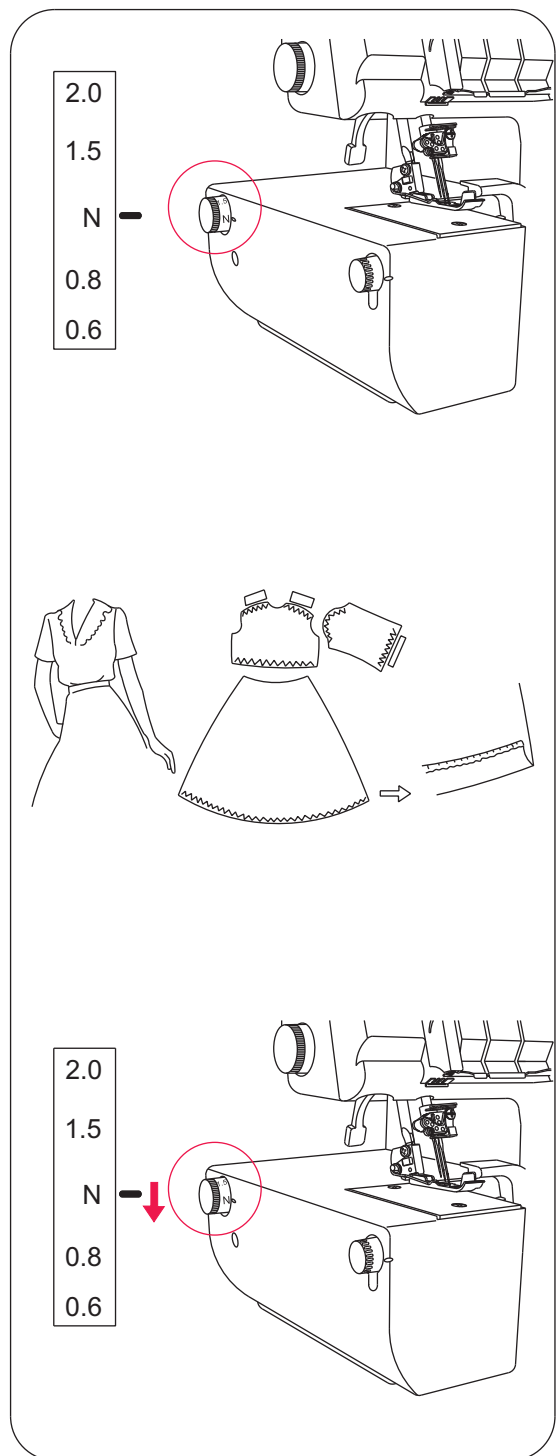

Stretch Overedge

- Stretch overedge is ideal for sewing decorative collars, sleeves, skirt hems, etc. on loosely knit and woven fabrics.

To set the differential feed adjusting dial for stretch

- Set differential feed adjusting lever knob above setting "N".

- To sew a seam, apply gentle tension to the fabric by holding the seam lightly in front and back of the presser foot.

Note: *if amount of "stretch" is not correctly set in relation to the fabric being sewn, the fabric is apt to shift away from the needle resulting in improperly sewn overedge seam. In such case, reset differential feed adjusting dial closer to the center mark.

*Be sure to reset the differential feed adjusting dial to graduation "N" for normal overedge stitching.

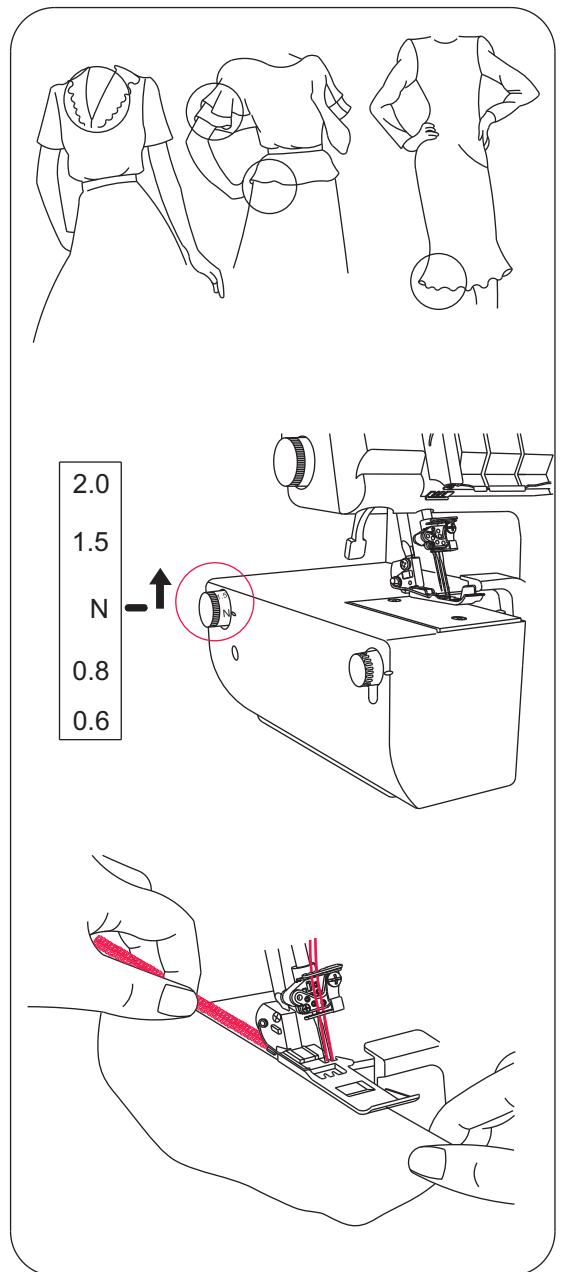

18. HOW TO DISENGAGE MOVABLE UPPER KNIFE



Caution:

Be sure to turn off power switch.

To place movable knife in nonworking position

- Open looper cover (page 12).
- Pull the movable knife holder to the right as far as it will go.
- Turn the holder toward counter clockwise until the knife clicks into a lock position.

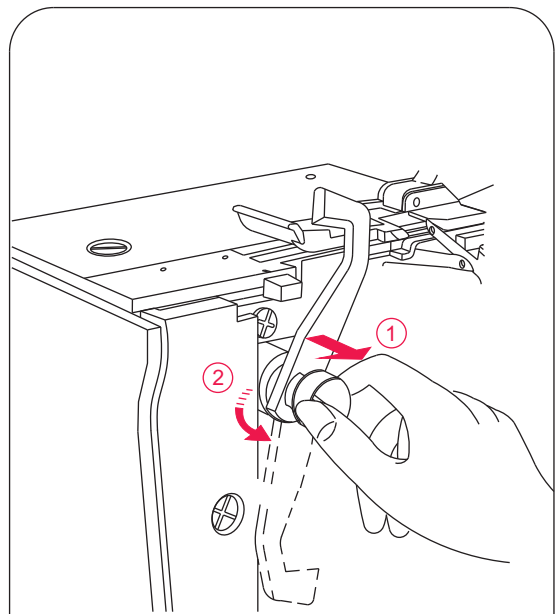

To place movable knife in working position

- Open looper cover.
- Pull the movable knife holder to the right as far as it will go.
- Turn the holder clockwise until the knife clicks into the working position.



Caution:

Always close looper cover before operating machine.

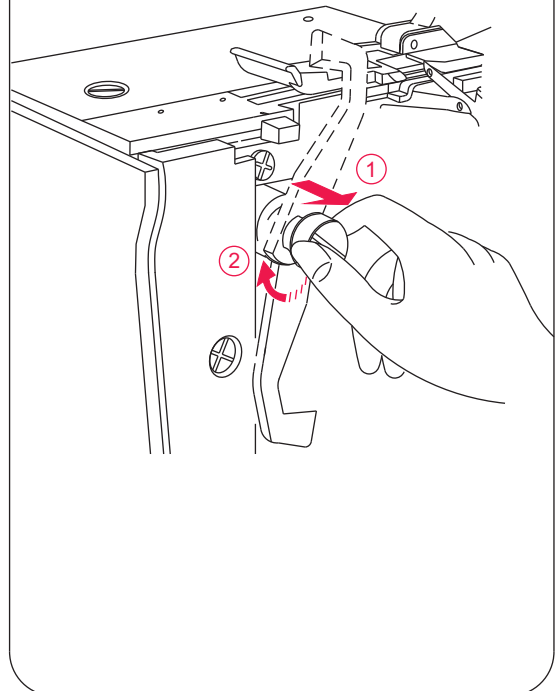

19. TO CONVERT UPPER LOOPER TO SPREADER



Caution:

Be sure to turn off power switch.

When not threading the upper looper, the spreader must be engaged into the upper looper eye.

To Use the Spreader

- To engage the spreader, raise the white handle on the spreader to insert the tip into the eye of upper looper.

- When using the upper looper, the spreader must be disengaged.

To Disengage to Upper Looper

- To disengage the spreader, lower the white handle on the spreader.

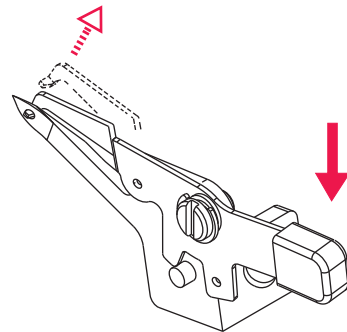
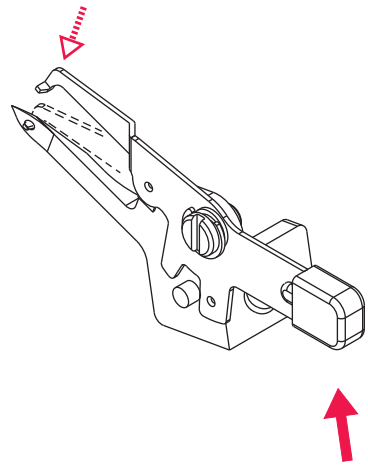

20. STANDARD OVEREDGE AND ROLLED HEM STITCHING

To Sew Standard Overedge

- Set seam width finger knob to N to move seam width finger to standard overedge sewing position.

Note: Be sure to push seam width finger knob as far as it will go in the direction of setting N.

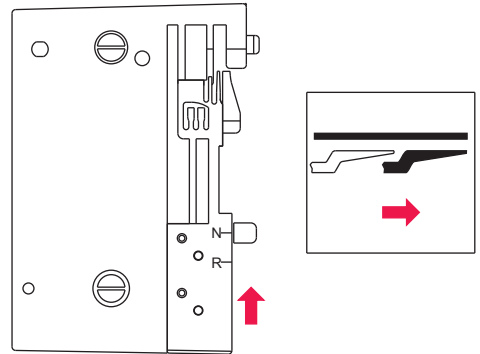

To Sew Rolled Hem

- Set seam width finger knob to R to retract the seam width finger and set it for rolled hem.

Note: Be sure to push seam width finger knob as far as it will go in the direction of setting R.

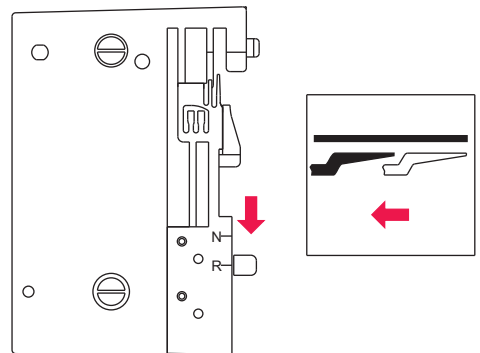

21. CHAINING OFF AND TEST SEWING

Note: The following instructions do not apply to cover stitch. For instructions on cover stitch, see page 49 "How to Sew a Cover Stitch."

- When the machine is completely threaded, bring all of the threads across the needle plate and slightly to the left under the presser foot.
- Hold the threads and apply a slight tension.
- Turn the hand wheel toward you 2 or 3 complete turns to start the thread chain.
- Lower presser foot by lowering presser bar lifter.
- Continue holding the chain and press on the foot controller until the chain is 5~7.5 cm (2~3 inches) in length.
- Place fabric under the front of the presser foot and sew a test sample.

Note: Do not pull on the fabric while sewing as this may deflect the needle, causing it to break.

- At the end of the sample, continue to run the machine with the presser foot down until the chain reaches 15 ~20 cm (6~8 inches) in length.

Note: In case it is difficult to chain off when chain stitching, pull the fabric lightly backward.

- Cut thread.

Note: Anytime you have rethreaded the machine always chain off and sew a text sample to test tensions and make adjustments as necessary.

Information

- A mark to indicate the needle location is provided on the presser foot fitted on this machine. Use this mark as a guide when sewing.

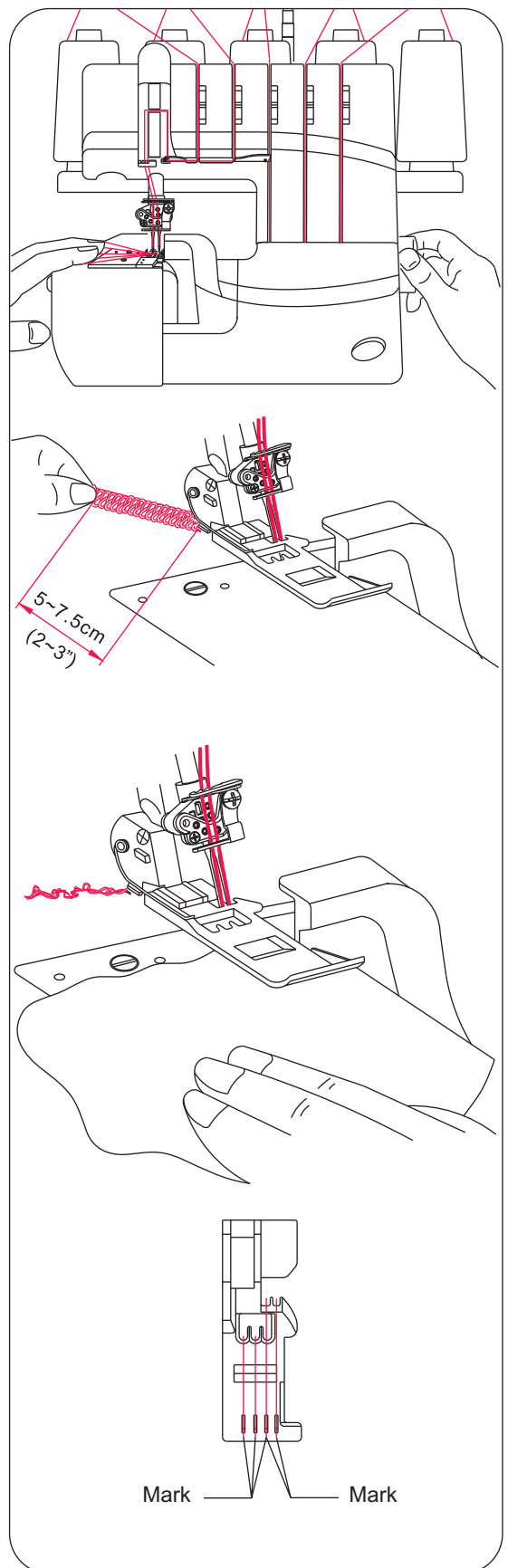

22. SETTINGS AND SEWING

1) Double Chain stitch

Tension is automatically set when selecting the desired stitch type with the Auto Tension Dial (ATD). Tension may be fine tuned with the Fine Tuning Levers according to the following variables:

- 1) Type and thickness of fabric
- 2) Needle size
- 3) Size, type and fibre content of thread

* Stitch length for double chain stitch should be set at over 2mm.

Correct Balance

- Set auto tension dial to D as shown on illustration and test sew on a sample of your fabric.

How to Balance

- When the chain stitch needle thread tension is too loose;
 - Move the needle thread tension fine tuning lever (blue) toward a higher position.
 - Or, move the chain stitch looper thread tension fine tuning lever (brown) toward a lower position.

ATD:D

NEEDLE POSITION	
SEAM WIDTH FINGER KNOB	R
STITCH LENGTH	2 ~ 4
DRIVING CULTCH POSITION	C

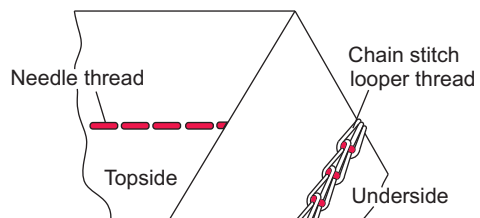

Fabric	Tension Dial				
	Orange	Blue	Green	Red	Brown
Medium weight		•			•

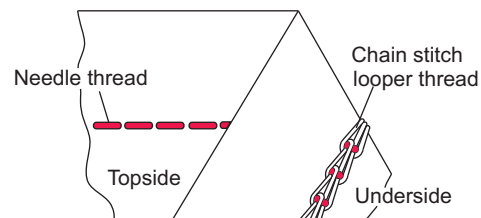

How to Sew

The double chain stitch is sewn with 2 threads, one needle and one looper. Normally, the machine trims the fabric edge while the seam is being sewn. However, a chain stitch seam can be placed at a desired distance from edge of fabric by putting the knife in a nonworking position, disengaging the upper looper and installing the chain stitch seam guide plate



Caution:

Be sure to turn off the power switch.

a) Move knife into nonworking position

- See page 35 for instructions on placing upper knife in nonworking position.

b) Disengage upper looper

- Turn handwheel till driving shaft is at its most right position, otherwise danger may occur.
- Push clutch button to the left and up for cover stitch / chain stitch or to the left and down for overlock.

c) To re-engage upper looper

- Turn handwheel till driving shaft is at its most right position, otherwise danger may occur.
- Push clutch button to the left and up for cover stitch / chain stitch or to the left and down for overlock.

d) To install the seam guide plate

- Open the looper cover
- Remove knife cover and install seam guide plate.
- The graduations on seam guide plate indicate the distance from chain stitch needle. Use this as a guide when checking the distance between cover stitch left needle and fabric edge.

e) Start and end of sewing

- When starting to sew, pull the thread chain lightly to the rear of machine until the needle penetrates the fabric.
- When starting to sew after threading the machine, sew 2 ~ 3 cm on a scrap fabric and chain-off to make a chain.
- At end of sewing, pull the fabric lightly to the rear of machine and chain-off.

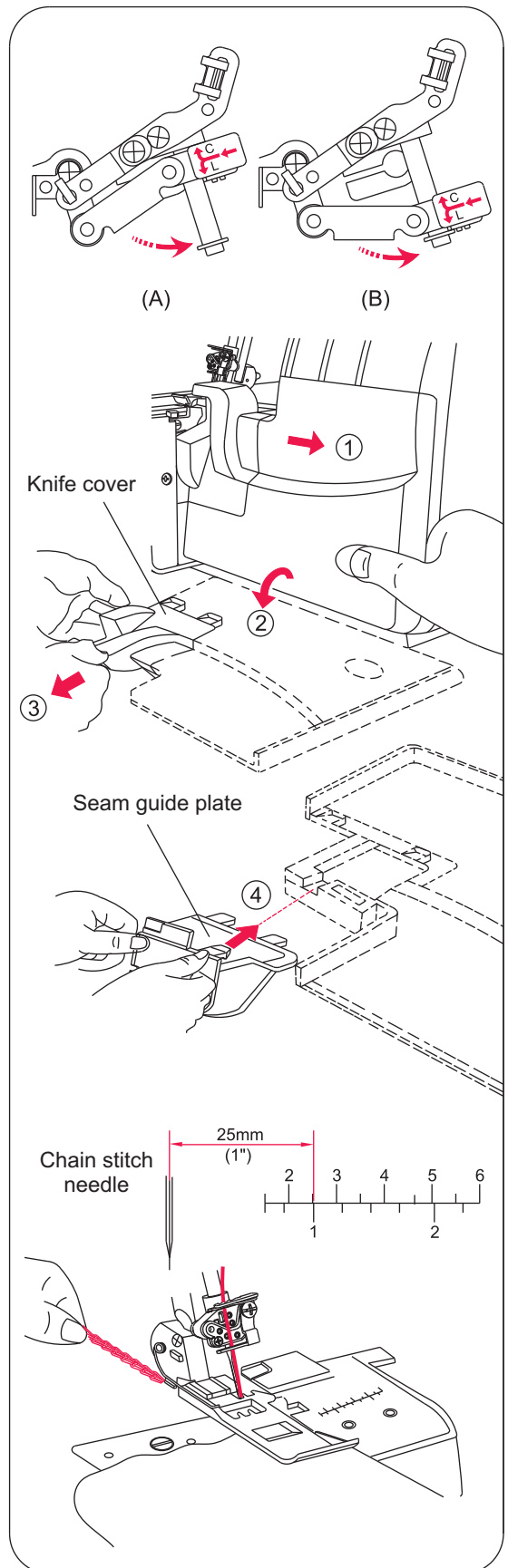

2) 2-thread Wrapped Edge Overlock

Tension is automatically set when selecting the desired stitch type with the Auto Tension Dial (ATD). Tension may be fine tuned with the Fine Tuning Levers according to the following variables:

- 1) Type and thickness of fabric
- 2) Needle size
- 3) Size, type and fibre content of thread

Correct Balance

- Set auto tension dial to D or G as shown on illustration and test sew on a sample of your fabric.

How to Balance

- When the lower looper thread tension is too tight or needle thread tension is too loose;
 - Move the lower looper thread tension fine tuning lever (red) toward a lower position.
 - Or, move the needle thread tension fine tuning lever (orange or blue) toward a higher position.

- When the lower looper thread tension is too loose;
 - Move the lower looper thread tension fine tuning lever (red) toward a higher position.

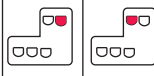
NEEDLE POSITION	
SEAM WIDTH FINGER KNOB	N
STITCH LENGTH	2 ~ 4
SPREADER	USE

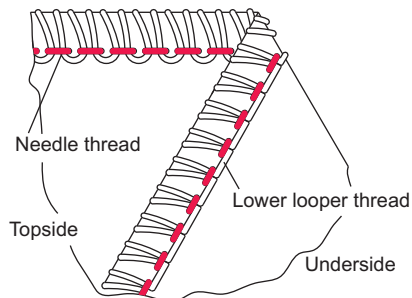

ATD:D

Fabric	Tension Dial				
	Orange	Blue	Green	Red	Brown
Medium weight		●	Spreader	●	

ATD:G

Fabric	Tension Dial				
	Orange	Blue	Green	Red	Brown
Medium weight	●		Spreader	●	

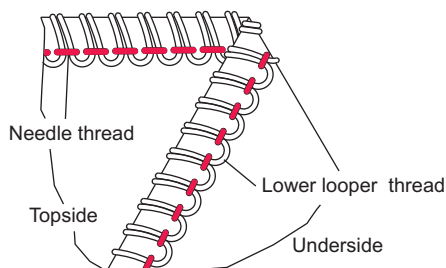
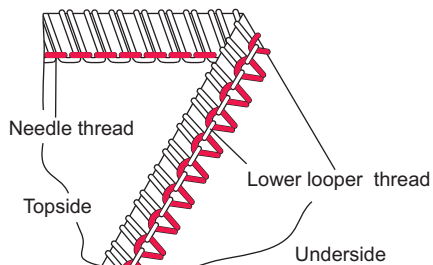

3) 2-thread Overedge

Tension is automatically set when selecting the desired stitch type with the Auto Tension Dial (ATD). Tension may be fine tuned with the Fine Tuning Levers according to the following variables:

- 1) Type and thickness of fabric
- 2) Needle size
- 3) Size, type and fibre content of thread

* See page 36 for instructions on converting upper looper to spreader.

Correct Balance

- Set auto tension dial to E as shown on illustration and test sew on a sample of your fabric.

How to Balance

- When the lower looper thread lies on the underside of the fabric;
 - Move the lower looper thread tension fine tuning lever (red) toward a higher position.
 - Or, move the needle thread tension fine tuning lever (orange or blue) toward a lower position.

- When the needle thread tension is too loose;
 - Move the needle thread tension fine tuning lever (orange or blue) toward a higher position.
 - Or, move the lower looper thread tension fine tuning lever (red) toward a lower position.

ATD:E

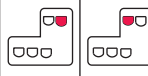
NEEDLE POSITION	
SEAM WIDTH FINGER KNOB	N
STITCH LENGTH	2~4
SPREADER	USE

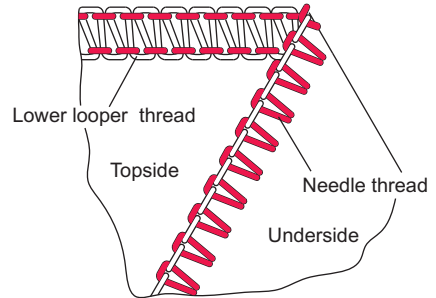

Fabric	Tension Dial				
	Orange	Blue	Green	Red	Brown
Medium weight		•	Spreader	•	

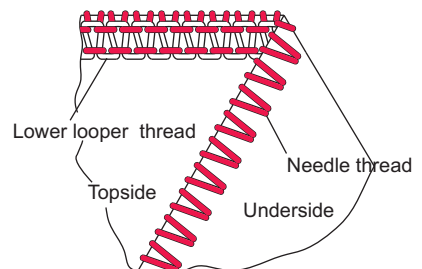
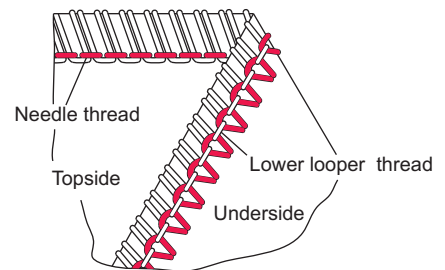

4) 3-thread Overlock

Tension is automatically set when selecting the desired stitch type with the Auto Tension Dial (ATD). Tension may be fine tuned with the Fine Tuning Levers according to the following variables:



- 1) Type and thickness of fabric
- 2) Needle size
- 3) Size, type and fibre content of thread

Correct Balance

- Set auto tension dial to A or B as shown on illustration and test sew on a sample of your fabric.

How to Balance

- When the upper looper thread lies on the underside of the fabric;
 - Move the upper looper thread tension fine tuning lever (green) to a higher position.
 - Or, move the lower looper thread tension fine tuning lever (red) to a lower position.
- When the lower looper thread appears on the top of the fabric;
 - Move the lower looper thread tension fine tuning lever (red) toward a higher position.
 - Or, move the upper looper thread tension fine tuning lever (green) to a lower position.
- When the needle thread is too loose, move the needle tension fine tuning lever (orange or blue) to a higher position.

NEEDLE POSITION		
SEAM WIDTH FINGER KNOB	N	
STITCH LENGTH	2~4	
SPREADER	N/A	

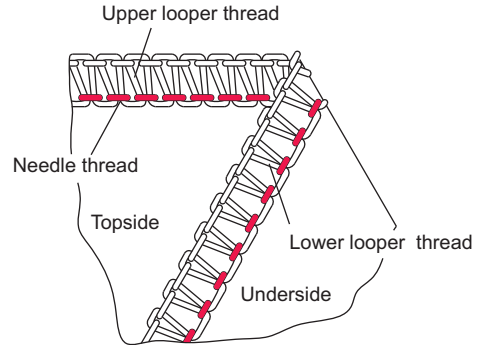

ATD:A

Fabric	Tension Dial				
	Orange	Blue	Green	Red	Brown
Medium weight		•	•	•	

ATD:B

Fabric	Tension Dial				
	Orange	Blue	Green	Red	Brown
Medium weight	•		•	•	

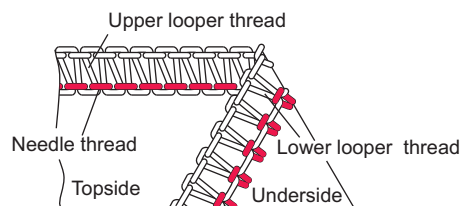
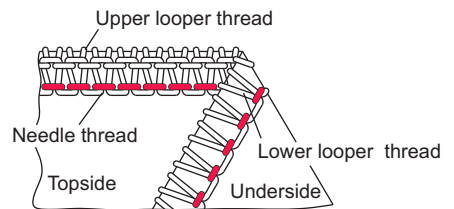
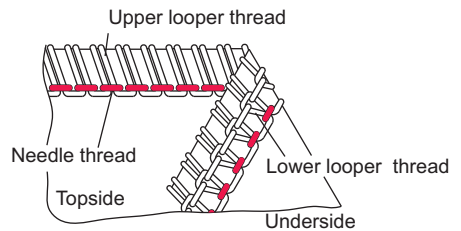

5) 3-thread Flatlock

Tension is automatically set when selecting the desired stitch type with the Auto Tension Dial (ATD). Tension may be fine tuned with the Fine Tuning Levers according to the following variables:

- 1) Type and thickness of fabric
- 2) Needle size
- 3) Size, type and fibre content of thread

Correct Balance

- Set auto tension dial to F as shown on illustration and test sew on a sample of your fabric.

How to Balance

- When the lower looper thread tension is too loose;
 - Move the lower looper thread tension fine tuning lever (red) toward a higher position.
 - Or, move the needle thread tension fine tuning lever (orange or blue) toward a lower position.
- When the upper looper thread tension is too loose;
 - Move the upper looper thread tension fine tuning lever (green) toward a higher position.
 - Or, move the needle thread tension fine tuning lever (orange or blue) toward a lower position.
- When the needle thread tension is too loose;
 - Move the needle thread tension fine tuning lever (orange or blue) toward a higher position.
 - Or, move the upper looper thread tension fine tuning lever (green) toward a lower position.

ATD:F

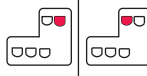
NEEDLE POSITION	
SEAM WIDTH FINGER KNOB	N
STITCH LENGTH	2~4
SPREADER	N/A

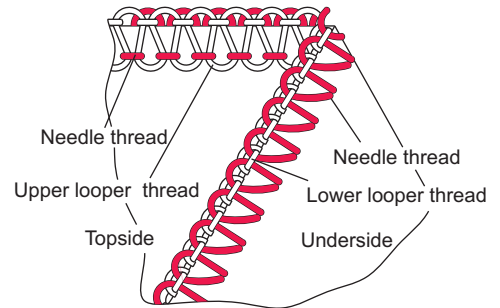

Fabric	Tension Dial				
	Orange	Blue	Green	Red	Brown
Medium weight		•	•	•	

Fabric	Tension Dial				
	Orange	Blue	Green	Red	Brown
Medium weight	•		•	•	

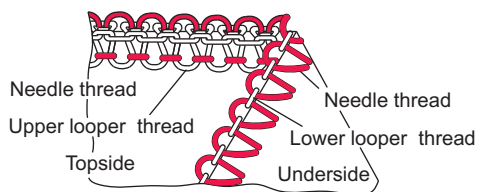
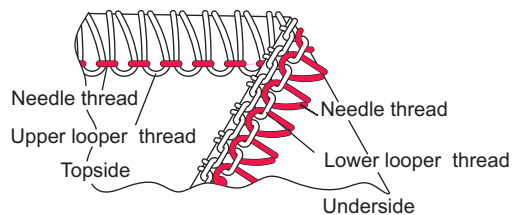
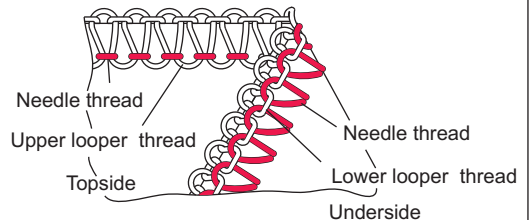

6) 3-thread Ultra Stretch Mock Safety Stitch

Tension is automatically set when selecting the desired stitch type with the Auto Tension Dial (ATD). Tension may be fine tuned with the Fine Tuning Levers according to the following variables:

- 1) Type and thickness of fabric
- 2) Needle size
- 3) Size, type and fibre content of thread

Correct Balance

- Set auto tension dial to G as shown on illustration and test sew on a sample of your fabric.

How to Balance

- When the lower looper thread tension is too loose;
 - Move the lower looper thread tension fine tuning lever (red) toward a higher position.

- When the left needle thread tension is too loose;
 - Move the left needle thread tension fine tuning lever (orange) toward a higher position.

- When the right needle thread tension is too loose;
 - Move the needle thread tension fine tuning lever (blue) toward a higher position.

ATD:G

NEEDLE POSITION	
SEAM WIDTH FINGER KNOB	N
STITCH LENGTH	2~4
SPREADER	USE

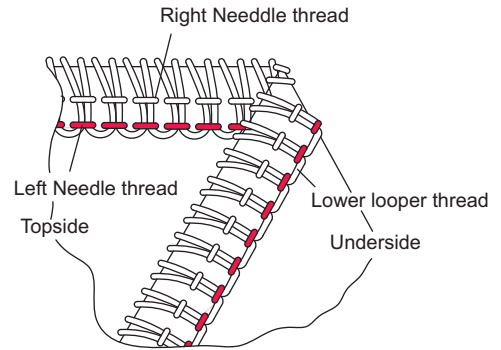

Fabric	Tension Dial				
	Orange	Blue	Green	Red	Brown
Medium weight	●	●	Spreader	●	

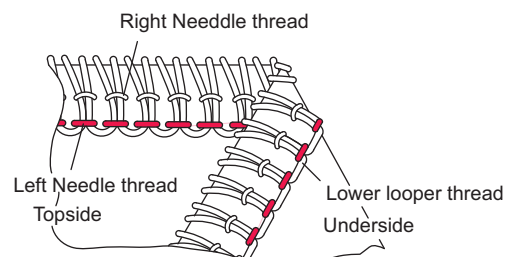
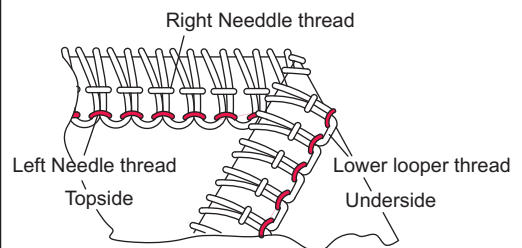
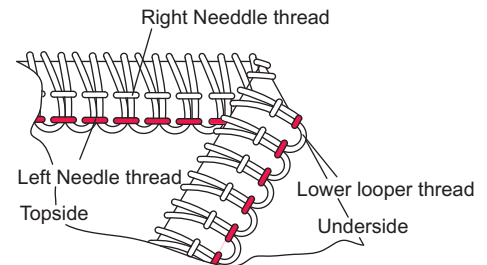

7) 4-thread Ultra Stretch Mock Safety Stitch

Tension is automatically set when selecting the desired stitch type with the Auto Tension Dial (ATD). Tension may be fine tuned with the Fine Tuning Levers according to the following variables:

- 1) Type and thickness of fabric
- 2) Needle size
- 3) Size, type and fibre content of thread

Correct Balance

- Set auto tension dial to A as shown on illustration and test sew on a sample of your fabric.

How to Balance

- When the upper looper thread lies on the underside of the fabric;
 - Move the upper looper thread tension fine tuning lever (green) toward a higher position.
 - Or, move lower looper thread tension fine tuning lever (red) to a lower position.
- When the lower looper thread appears on the top of the fabric;
 - Move the lower looper thread tension fine tuning lever (red) toward a higher position.
 - Or, move the upper looper thread tension fine tuning lever (green) toward a lower position.
- When the left needle thread tension is too loose;
 - Move the needle thread tension fine tuning lever (orange) toward a higher position.
- When the right needle thread tension is too loose;
 - Move the right needle thread tension fine tuning lever (blue) toward a higher position.

ATD:A

NEEDLE POSITION	
SEAM WIDTH FINGER KNOB	N
STITCH LENGTH	2~4
SPREADER	N/A

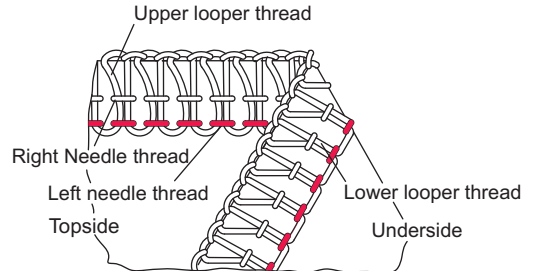

Fabric	Tension Dial				
	Orange	Blue	Green	Red	Brown
Medium weight	●	●	●	●	

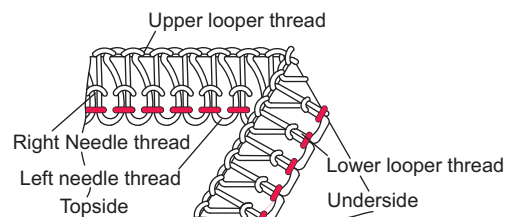
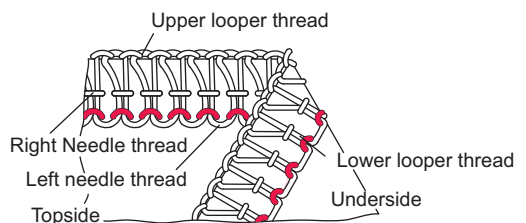
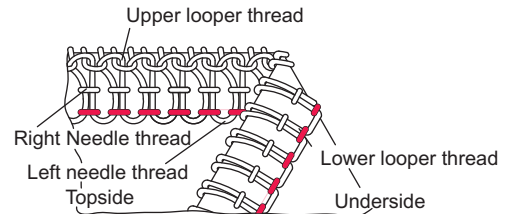
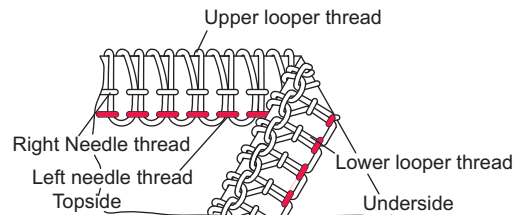

8) 4-thread Safety Stitch

Tension is automatically set when selecting the desired stitch type with the Auto Tension Dial (ATD). Tension may be fine tuned with the Fine Tuning Levers according to the following variables:

- 1) Type and thickness of fabric
- 2) Needle size
- 3) Size, type and fibre content of thread

Correct Balance

- Set auto tension dial to I as shown on illustration and test sew on a sample of your fabric.

How to Balance

- When the lower looper thread appears on the top of the fabric;
 - Move the lower looper thread tension fine tuning lever (red) to a higher position.
 - Or, move the upper looper thread tension fine tuning lever (green) toward a lower position.
- When the right needle thread is too loose;
 - Move the right needle thread tension fine tuning lever (blue) toward a higher position.
- When the chain stitch needle thread tension is too loose;
 - Move the chain stitch needle thread tension fine tuning lever (orange) toward a higher position.
 - Or, move the chain stitch looper thread tension fine tuning lever (brown) toward a lower position.

ATD:I

NEEDLE POSITION	
SEAM WIDTH FINGER KNOB	N
STITCH LENGTH	2~4
SPREADER	USE

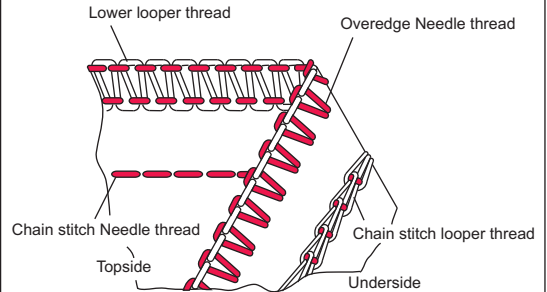

Fabric	Tension Dial				
	Orange	Blue	Green	Red	Brown
Medium weight	•	•	Spreader	•	•

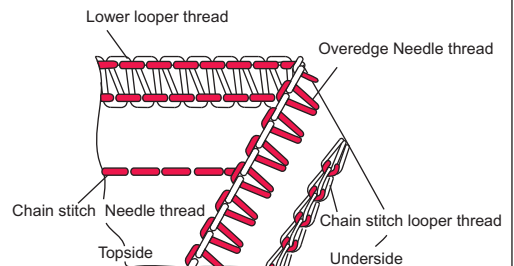
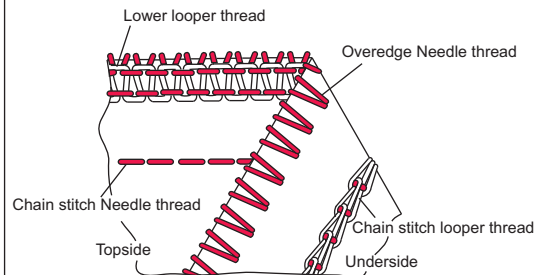
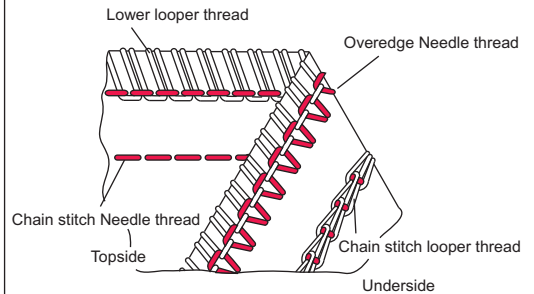

9) 5-thread Safety Stitch

Tension is automatically set when selecting the desired stitch type with the Auto Tension Dial (ATD). Tension may be fine tuned with the Fine Tuning Levers according to the following variables:

- 1) Type and thickness of fabric
- 2) Needle size
- 3) Size, type and fibre content of thread

Correct Balance

- Set auto tension dial to B as shown on illustration and test sew on a sample of your fabric.

How to Balance

- When the upper looper thread lies on the underside of the fabric;
 - Move the upper looper thread tension fine tuning lever (green) to a higher position.
 - Or, move lower looper thread tension fine tuning lever (red) to a lower position.
- When the lower looper thread appears on the top of the fabric;
 - Move the lower looper thread tension fine tuning lever (red) toward a higher position.
 - Or, move the upper looper thread tension fine tuning lever (green) toward a lower position.
- When the left needle thread tension is too loose;
 - Move the left needle thread tension fine tuning lever (blue) toward a higher position.
- When the chain stitch needle thread tension is too loose;
 - Move the chain stitch needle thread tension fine tuning lever (orange) toward a higher position.
 - Or, move the chain stitch looper thread tension fine tuning lever (brown) toward a lower position.

ATD:B

NEEDLE POSITION	
SEAM WIDTH FINGER KNOB	N
STITCH LENGTH	2 ~ 4
SPREADER	N/A

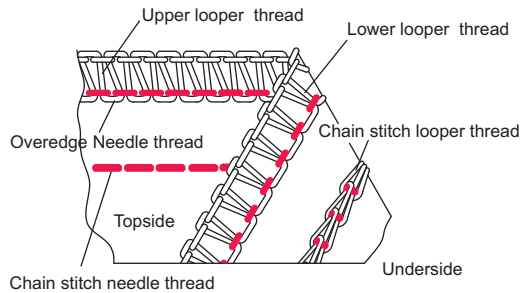

Fabric	Tension Dial				
	Orange	Blue	Green	Red	Brown
Medium weight	●	●	●	●	●

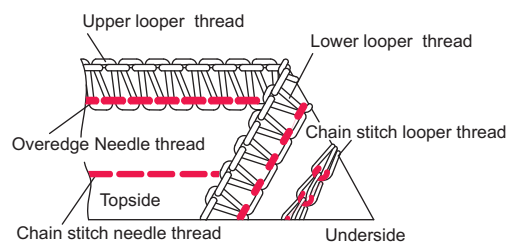
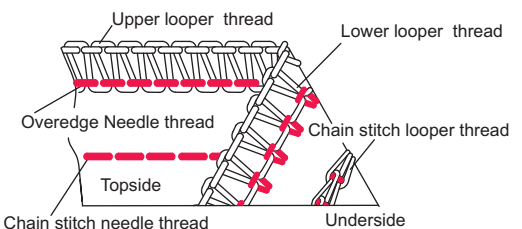
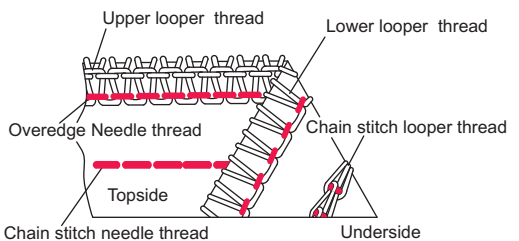
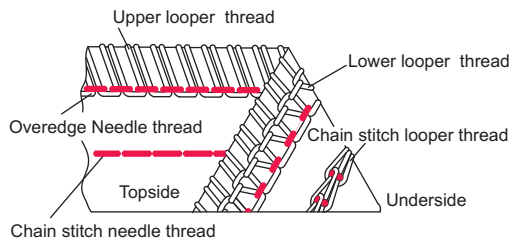

23. HOW TO SEW A COVER STITCH

- This machine can produce a 3-thread 5.6 mm wide bottom cover stitch.
- The cover stitch can be used for covering, binding or top-stitching necklines and for hemming the bottom, of T-shirts and sweat suits, etc. in addition to flat joining seams (plain seaming).
- The cover stitch is most suitable for stretchy fabrics such as knit.
- It also can be used in woven fabrics such as denim, but careful attention must be paid to the tension settings or there is the possibility of thread breakage and or skipping.
- If you experience skipping or thread breakage sewing denim change needles first and then adjust the tensions little by little (1/4 number at a time).

Machine Set up



Caution:

Be sure to turn off the power switch.

- Open looper cover. (See page 12)
- Disengage upper looper. (See page 40)
- Place the movable upper knife in the non working position. (See page 35)
- Set seam width finger knob on "R" side. (See page 37) Set C/L clutch (see page 40).
- Remove overedge right needle (B) and overedge left needle (A).
- For Triple 5.6mm cover stitch, install cover stitch right needle (E), cover stitch middle needle (D) and cover stitch left needle (C). (See pages 25 ~ 29)
- Pass thread through needles (E), (D) and (C) and thread cover stitch looper [brown] (See pages 20 ~ 21)
- Install seam guide plate. (See page 40)
- The graduations on seam guide plate indicate the distance from cover stitch middle needle. Use it as a guide when positioning fabric edge.
- The holes in the seam guide plate are designed to attach accessories that might be introduced in the future, please check back with your retailer about availability.
- Close looper cover.

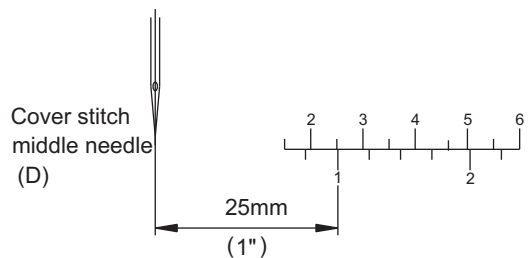
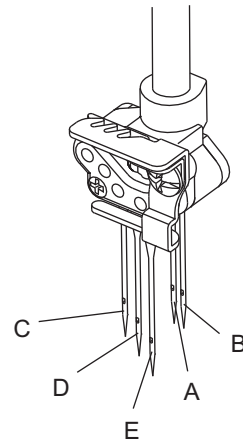
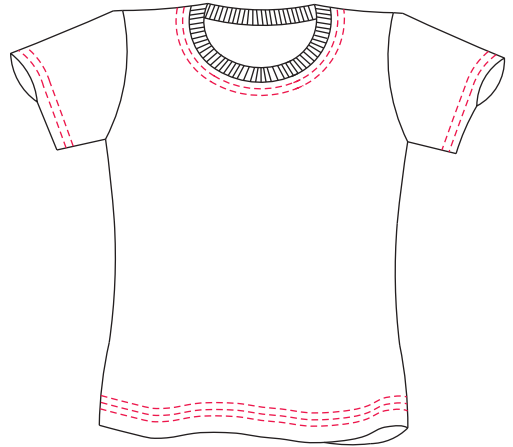

Additional Information About Cover Stitch

Start and end of sewing

Note: Follow the instructions given below when sewing cover stitches because chaining-off at the end of sewing is not possible.

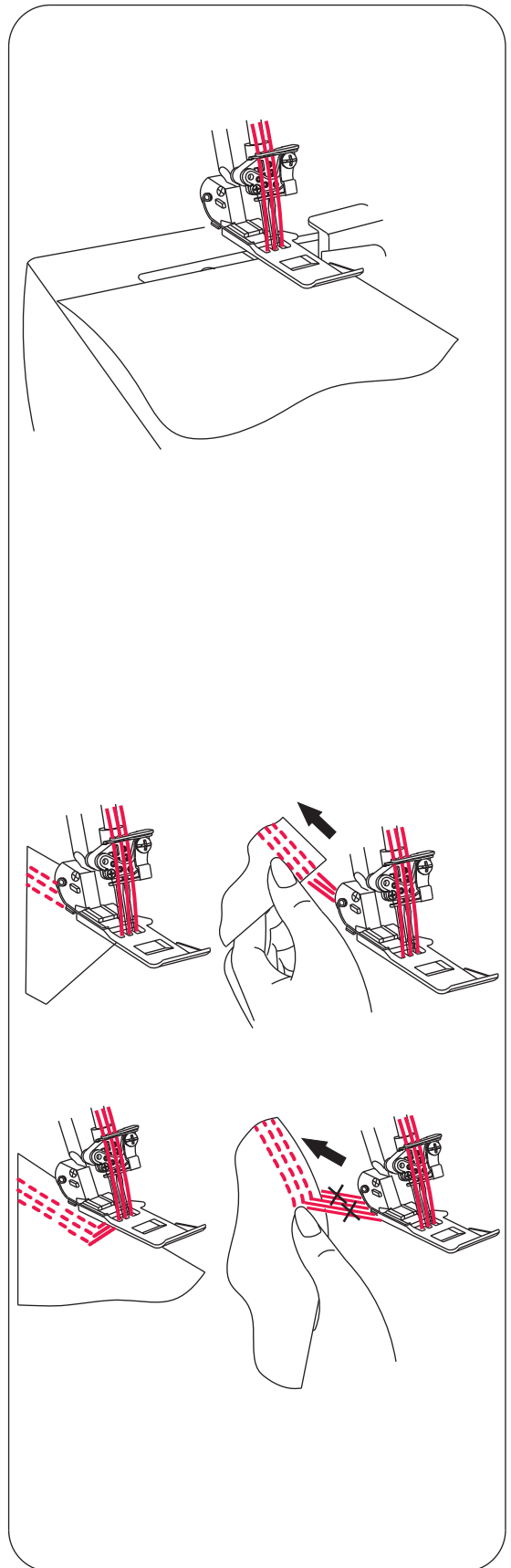

At start of sewing

- Raise presser foot by lowering the presser bar lifter.
- Place material under presser foot behind the needle.
- Lower presser foot by raising the presser bar lifter.

Note: When you start to sew from the middle of the fabric, place the fabric at the desired starting point of sewing.

2-Thread Cover Stitch Suggested Tension Settings

Tension is automatically set when selecting the desired stitch type with the Auto Tension Dial (ATD). Tension may be fine tuned with the Fine Tuning Levers according to the following variables:

- 1) Type and thickness of fabric
- 2) Needle size
- 3) Size, type and fibre content of thread

* Stitch length for cover stitch should be set at over N (2.5 mm).

Correct Balance

- Set auto tension dial to K or H as shown on illustration and test sew on a sample of your fabric.

How to Balance

- When the cover stitch looper thread is too loose;
 - Move the cover stitch looper thread tension fine tuning lever (brown) toward a higher position.
- When the cover stitch left needle thread tension is too loose;
 - Move the cover stitch left needle thread tension fine tuning lever (orange) toward a higher position.
 - Or, move cover stitch looper thread tension fine tuning lever (brown) toward a lower position.
- When the cover stitch right needle thread tension is too loose;
 - Move the cover stitch right needle thread tension fine tuning lever (blue) or (orange) toward a higher position.
 - Or, move the cover stitch looper thread tension fine tuning lever (brown) toward a lower position.
- When the top surface of fabric bulges between needle threads and the seams on the underside of the fabric becomes tight;
 - move the cover stitch looper thread tension fine tuning lever (brown) toward a lower position.

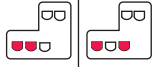
NEEDLE POSITION	
SEAM WIDTH FINGER KNOB	R
STITCH LENGTH	N~4
DRIVING CLUTCH POSITION	C

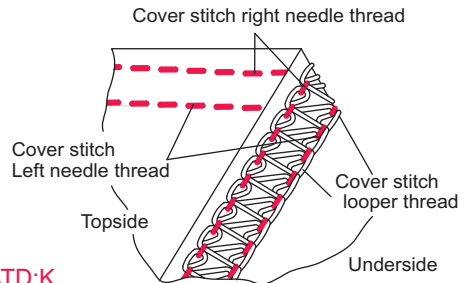

ATD:K

Cover stitch looper Thread	Tension Dial				
	Orange	Blue	Green	Red	Brown
Polyester	•	•			•
Woolly nylon	•	•			•

ATD:H

Cover stitch looper Thread	Tension Dial				
	Orange	Blue	Green	Red	Brown
Polyester	•		•		•
Woolly nylon	•		•		•

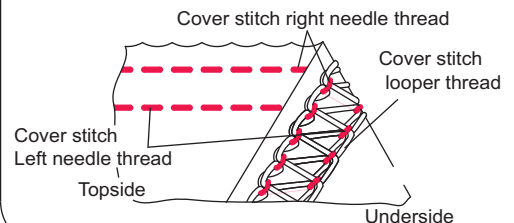
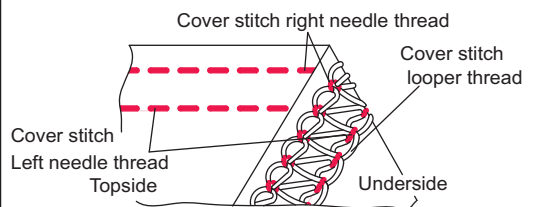
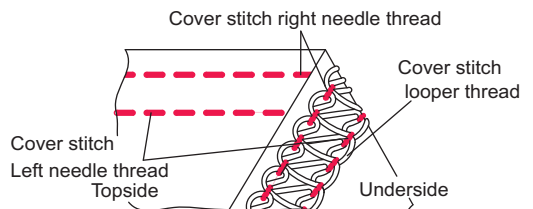
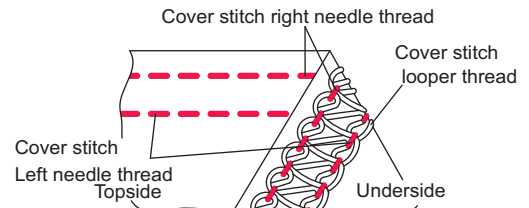

3-Thread Cover Stitch Suggested Tension Settings

Tension is automatically set when selecting the desired stitch type with the Auto Tension Dial (ATD). Tension may be fine tuned with the Fine Tuning Levers according to the following variables:

- 1) Type and thickness of fabric
- 2) Needle size
- 3) Size, type and fibre content of thread

* Stitch length for cover stitch should be set at over N (2.5 mm).

Correct Balance

- Set auto tension dial to J as shown on illustration and test sew on a sample of your fabric.

How to Balance

- When the cover stitch looper thread is too loose;
 - Move the cover stitch looper thread tension fine tuning lever (brown) toward a higher position.
- When the cover stitch left needle thread tension is too loose;
 - Move the cover stitch left needle thread tension fine tuning lever (orange) toward a higher position.
 - Or, move cover stitch looper thread tension fine tuning lever (brown) toward a lower position.
- When the cover stitch middle needle thread tension is too loose;
 - Move the cover stitch middle needle thread tension fine tuning lever (blue) toward a higher position.
 - Or, move cover stitch looper thread tension fine tuning lever (brown) toward a lower position.
- When the cover stitch right needle thread tension is too loose;
 - Move the cover stitch right needle thread tension fine tuning lever (green) toward a higher position.
 - Or, move the cover stitch looper thread tension fine tuning lever (brown) toward a lower position.
- When the top surface of fabric bulges between needle threads and the seams on the underside of the fabric becomes tight;
 - move the cover stitch looper thread tension fine tuning lever (brown) toward a lower position.

ATD:J

NEEDLE POSITION	
SEAM WIDTH FINGER KNOB	R
STITCH LENGTH	N~4
DRIVING CLUTCH POSITION	C

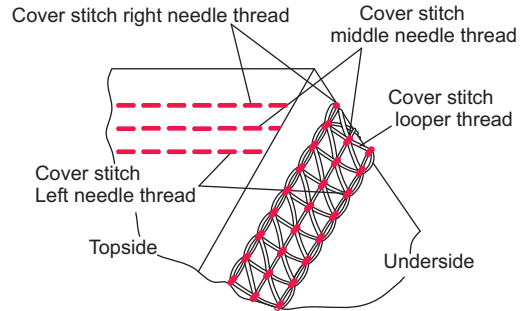

Cover stitch looper Thread	Tension Dial				
	Orange	Blue	Green	Red	Brown
Polyester	●	●	●		●
Woolly nylon	●	●	●		●

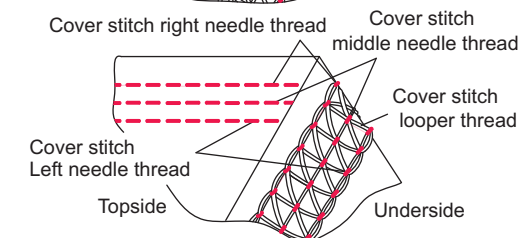
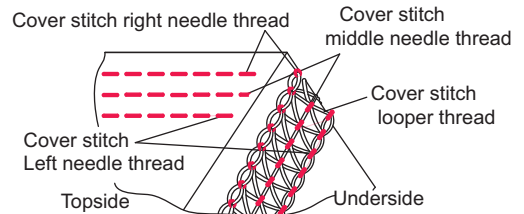
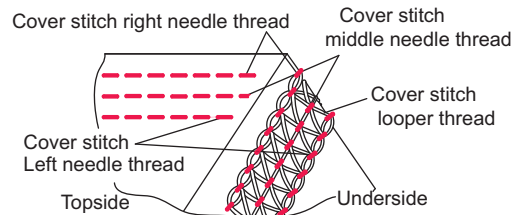
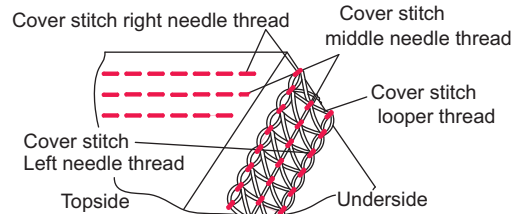

Securing the seam end

Since the seams formed by cover stitch unravel when the looper thread is pulled out at the end of sewing, secure the seam end in the following manner.

- When sewing through to the edge of fabric, among the threads coming out of the fabric edge, knot the needle threads (2 or 3 threads) together first, as shown on the illustration. Then, tie these threads with the looper threads.

- When sewing is stopped halfway, pull out the needle threads (2 or 3 threads) on the underside of the fabric and knot the threads in the same manner as described above.

- Cut extra threads.

Note: Normally, the seams at the start of sewing do not unravel, but it is safe to secure the seam end following the same steps as described when sewing through to the edge of fabric.

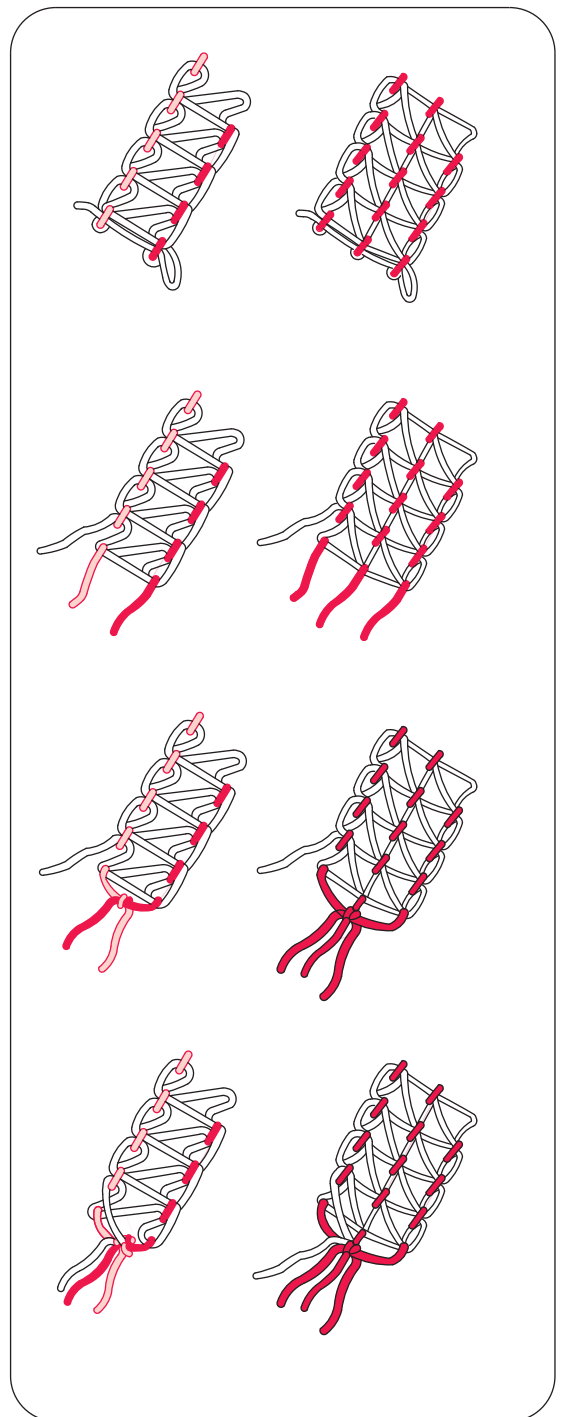

24. HOW TO SEW A ROLLED HEM

- This machine can sew four types of rolled hems.
- Rolled hemming is done by rolling and overedging the fabric edge.
- Light weight fabrics such as lawn, voile, organdy, crepe, etc. perform the best.
- Rolled hemming is not suited for heavy or stiff fabrics.

NOTE: Rolled hemming can only be performed with the overedge right needle.

Machine Set up



Caution:

Be sure to turn off power switch.

- Remove the overedge left needle, chain stitch needle and cover stitch needle(s).
- Move seam width finger knob to setting R.
- Align left face of seam width finger support plate with R mark on needle plate by turning seam width adjustment knob, as required.
- Set stitch length dial to "1~2" and a fine seam will be sewn.
- Needle: Singer Cat. No. 2022 #14/90 or 2022 #11/80
- Thread: A variety of thread combinations can be used for rolled hemming.

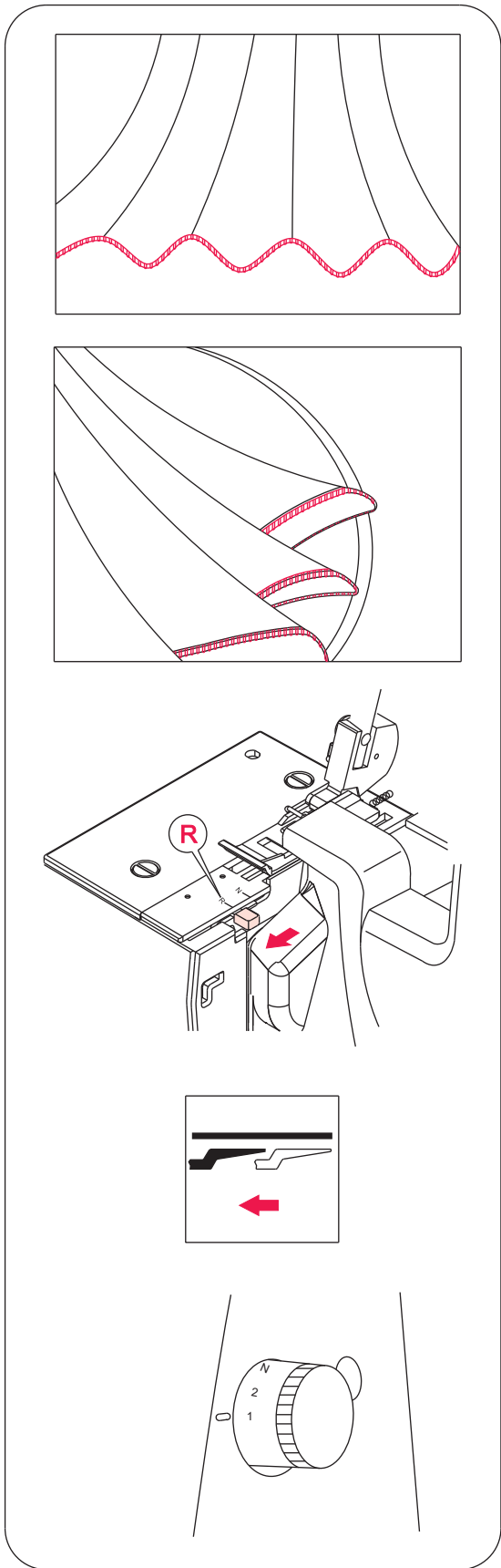

Note: For a beautiful rolled hem thread the upper looper with woolly nylon and the needle and lower looper with lightweight regular thread.

1) 3-thread Standard Rolled Hem Stitching

Correct Balance

- Set auto tension dial to A as shown on illustration and test sew on a sample of your fabric.

NEEDLE POSITION	
SEAM WIDTH FINGER KNOB	R
STITCH LENGTH	1~2
DRIVING CLUTCH POSITION	L

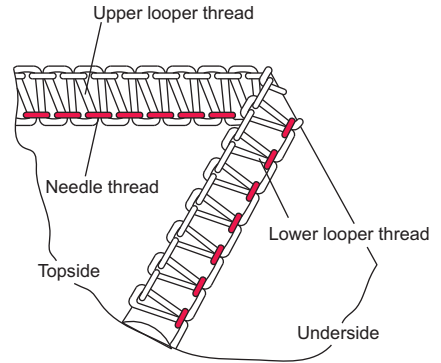

ATD:A

Light Weight fabric	Tension Dial				
	Orange	Blue	Green	Red	Brown
Polyester		•	•	•	
Woolly nylon		•	•	•	

2) 3-thread Upper Looper Thread Wrapped Rolled Hem Stitching

Correct Balance

- Set auto tension dial to C as shown on illustration and test sew on a sample of your fabric.

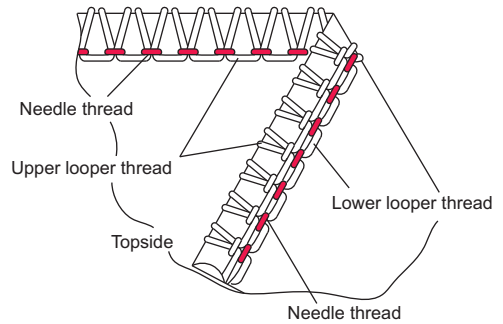

ATD:C

Light Weight fabric	Tension Dial				
	Orange	Blue	Green	Red	Brown
Polyester		•	•	•	
Woolly nylon		•	•	•	

Note: For a beautiful rolled hem thread the lower looper with wooly nylon and the needle with lightweight regular thread.

- Convert upper looper to spreader. (See page 36)

3) 2-thread Standard Rolled Hem Stitching

Correct Balance

- Set auto tension dial to E as shown on illustration and test sew on a sample of your fabric.

NEEDLE POSITION	
SEAM WIDTH FINGER KNOB	R
STITCH LENGTH	1~2
SPREADER	USE

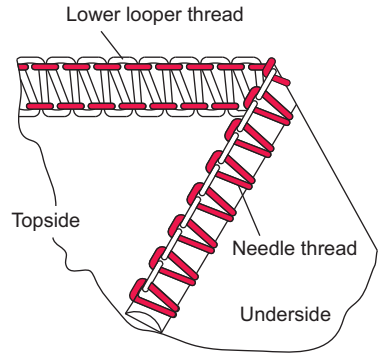

ATD:E

Light Weight fabric	Tension Dial				
	Orange	Blue	Green	Red	Brown
Woolly nylon		●	Spreader	●	

4) 2-thread Lower Thread Wrapped Rolled Hem Stitching

Correct Balance

- Set auto tension dial to D as shown on illustration and test sew on a sample of your fabric.

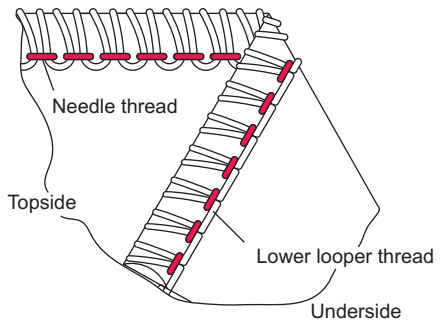

ATD:D

Light Weight fabric	Tension Dial				
	Orange	Blue	Green	Red	Brown
Polyester		●	Spreader	●	
Woolly nylon		●	Spreader	●	

Additional Information About Rolled Hemming

- Hold the thread chain when you begin sewing to keep it from curling into the seam.
- Place a slight tension on the material in the sewing direction and a finer seam finish can be obtained.
- The minimum overedge stitch width that can be obtained for rolled hemming is approximately 1.5 mm (1/16 inch) since the cutting width cannot be set below 3.5 mm (9/64 inch).

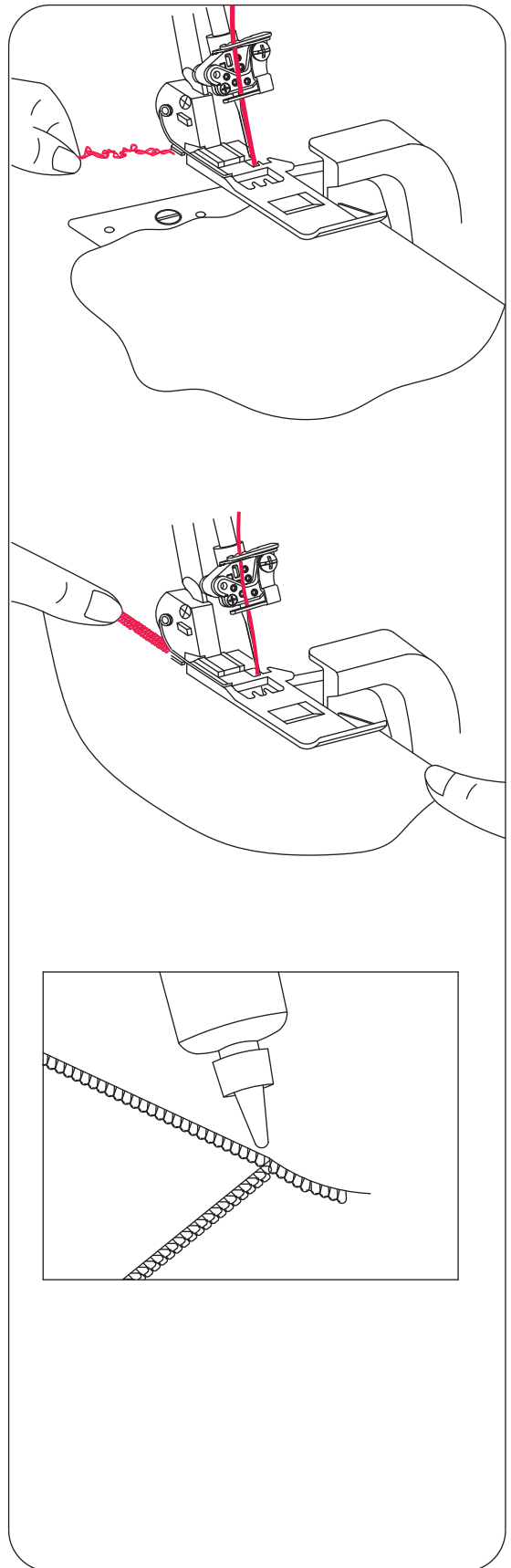

To Secure the Rolled Hem Thread Chain

- Apply a small drop of liquid seam sealant to the end of the seam. Allow to dry, then cut the chain close to the stitches.

Note: Test the liquid seam sealant for color fastness before use.

25. STITCH VARIATIONS AND SEWING TECHNIQUES

How to Sew a Flatlock Decorative Seam

- A flatlock stitch is achieved by adjusting the tension of the 2-thread or 3-thread overlock stitch, sewing the seam, and then pulling the fabric apart to flatten the seam.
- The flatlock stitch can be used as a construction and decorative stitch or for ornamentation only.

1) Machine Set Up

- Use either overedge right needle or overedge left needle.
- Begin with the machine threaded and tension ATD-E balanced for the 2-thread overedge (page 42) or 3-thread flatlock stitch ATD-F (page 44).

2) Flatlocking a Seam

- Place the fabric wrong sides together to sew a decorative stitch on the right side of the garment.
- Sew the seam, trimming the excess fabric.
- The needle thread (orange or blue) will form a V on the underside of the fabric.
- The lower looper thread will pull into a straight line at the fabric edge.
- Pull on opposite sides of the seam to pull the stitches flat.

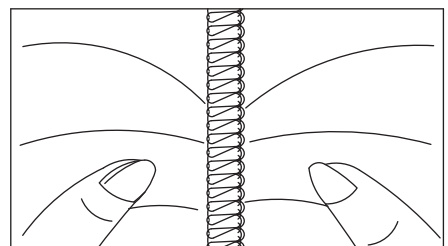
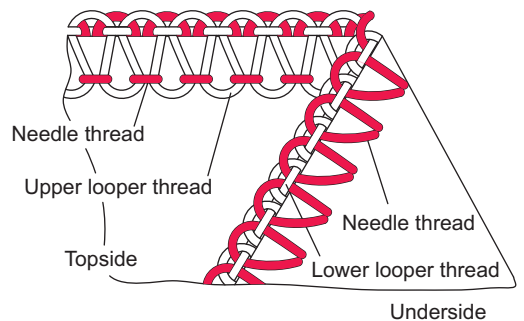
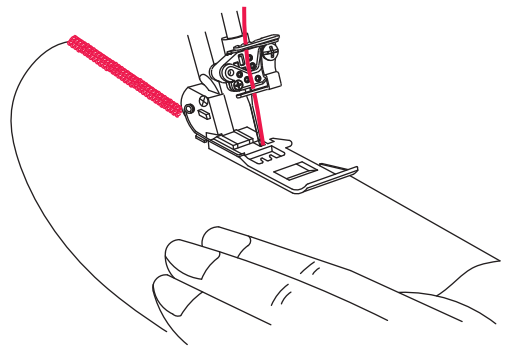
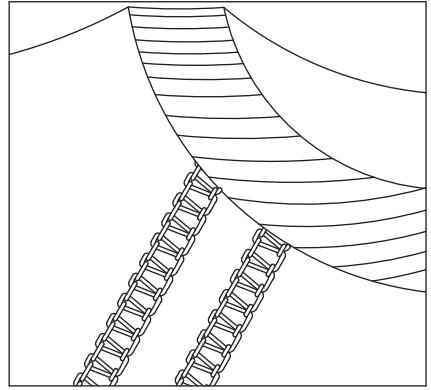

(3) Decorative Flatlocking

- Place the movable upper knife in the nonworking position (page 35). The fabric is not trimmed on this stitch.

- Fold fabric wrong sides together.
- Position the fabric so the seam is sewn with part of the stitch extending off the fabric.

- Pull on opposite sides of the stitch to flatten.

(4) Additional Information About Flatlocking

- The tensions must be correctly fine tuned for the fabric to pull flat.
- The upper looper thread is the prominent thread in the flatlock stitch. Place a decorative thread in the upper looper and inconspicuous threads in the lower looper and needle.
- For a ladder stitch, sew seam with right sides together. The needle thread will be the prominent thread that creates the ladder (A).

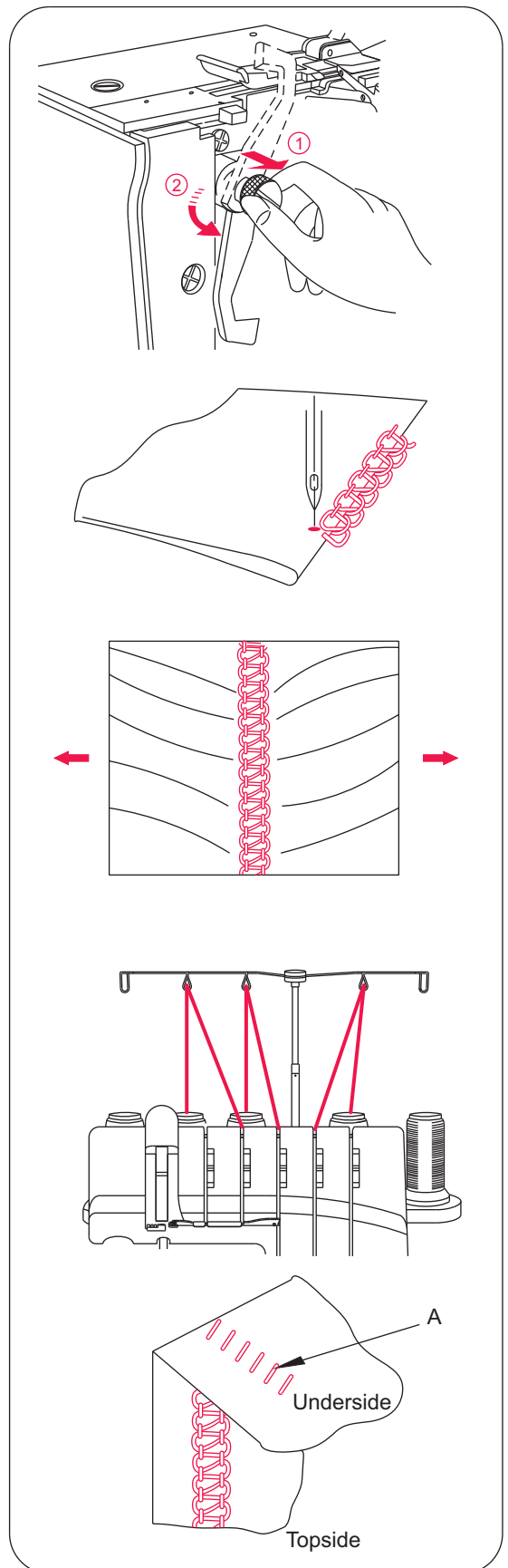

How to Sew an Overlock Blind Hem

- The excess fabric is trimmed and the hem is sewn and the raw edges are overlocked in one operation.
- The overlock blind hem is best suited for sewing knit wear. It provides a durable finish that is almost invisible.
- Use overedge right needle and adjust machine for a narrow 3-thread overlock stitch. (See page 43)

Note: The three-thread flatlock stitch can also be used.
(See page 44)

- Set the stitch length dial at 4
- Fold the hem to the wrong side of the fabric, then back to the right side with 6 mm (1/4 inch) beyond the fold.
- Stitch on the extended hem edge, allowing the machine needle to barely catch the edge of the fold.

Note: An optional blindstitch foot is available.
(See page 68)

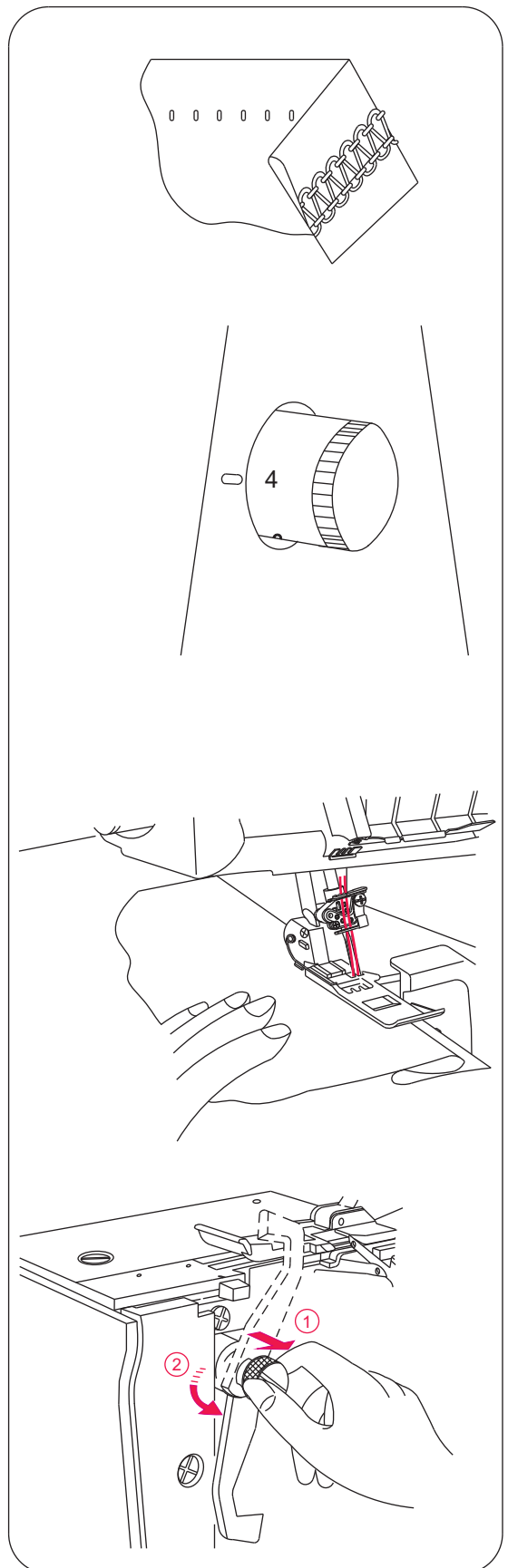

How to Sew Pin Tucks

- Sew decorative pin tucks on the fabric before cutting out the garment.
- Use overedge right needle and adjust machine for a narrow 3-thread overlock stitch. (See page 43)

Note: The rolled hemstitch can also be used for this technique.

- Place the movable upper knife in the nonworking position. (See page 35)
- Mark the fabric with the desired number of pin tucks using a water-soluble fabric marker

- Fold the fabric with the wrong sides together and sew.

- Press the pin tucks in the same direction.

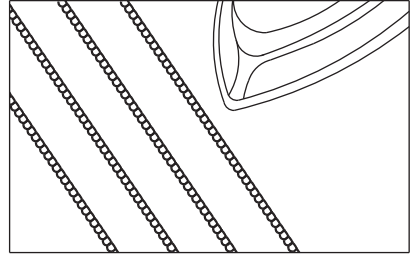
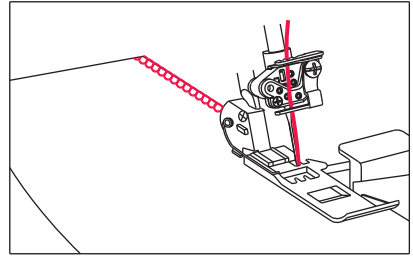

Turning Square Corners

(1) Outside Corner

- Cut out approximately 2cm (51/64 inch) from the corner, in line with the overedge seam edge.
- Sew one stitch beyond point (A) and stop.
- Raise needle and presser foot.
- Pull the fabric to the rear of the machine just enough to release the thread caught on the finger of the needle plate.

Note: Presser foot has been removed to show detail.

- Turn the fabric and lower the presser foot so that the knife is positioned in line with the cut edge.
- Pull slack threads up, then start to sew.

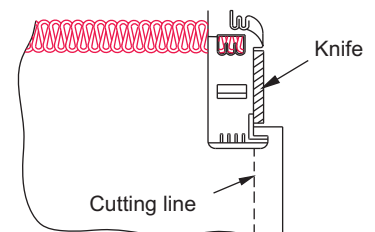
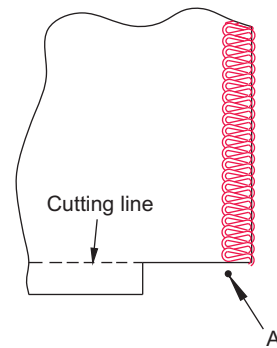
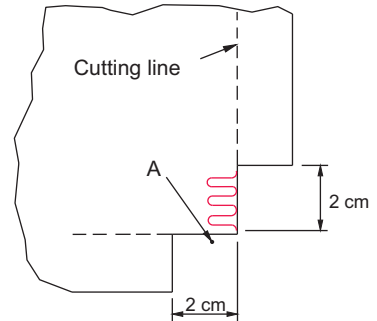

(2) Inside Corner

- Cut inside corner up to seam line as shown
- Sew along seam line.
- Sew up to end of fold. (Leave needle in fabric)
- Raise presser foot. (Leave needle in fabric)
- Spread fold and re-fold so that seam line is straight.

Pin Placement

- Insert pins to the left of the presser foot. The pins will be easy to remove and are away from the cutting action of the knives.



Caution:

Sewing over pins will damage and /or destroy the cutting edge of the knives.

Securing the Thread Chain

- Thread a large eye, hand sewing needle (such as a tapestry needle) with the thread chain.
- Insert the needle into the end of the seam to secure thread.
- Note: To secure a rolled hem thread chain, see page 57.

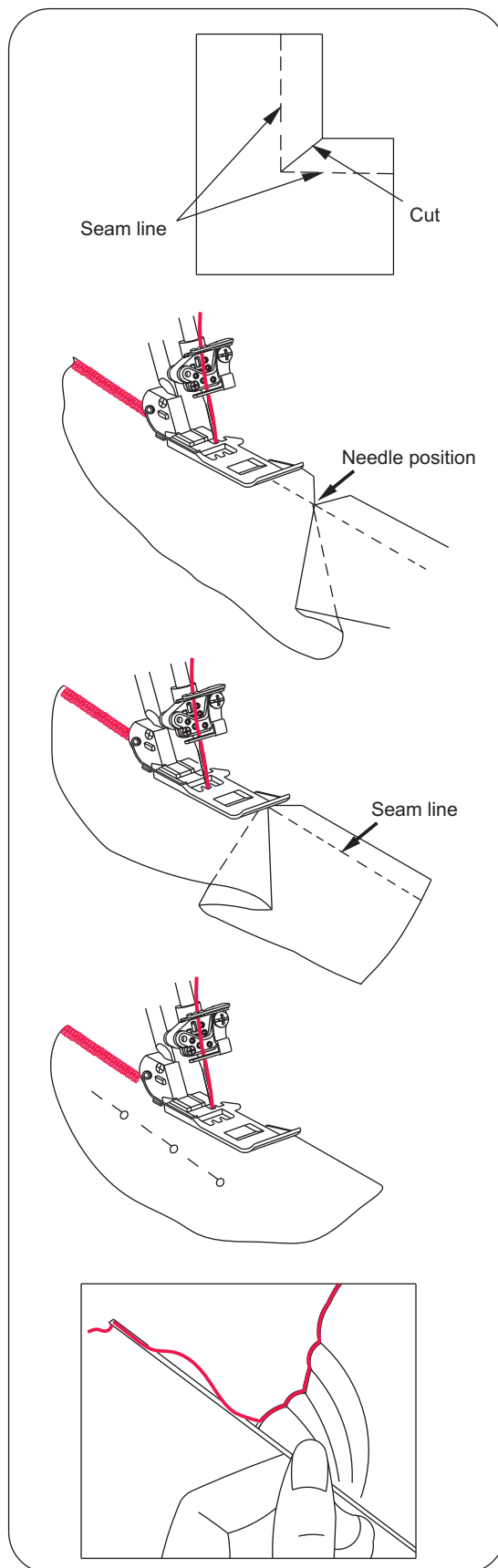

How to Reinforce a Seam

- Inserting twill tape while overedge sewing will stabilize the seam.
- Insert the tape through the hole in the front of the foot.
- Position the tape under the foot to the back of the machine and sew the garment seam.

- The tape is attached as the seam is sewn.

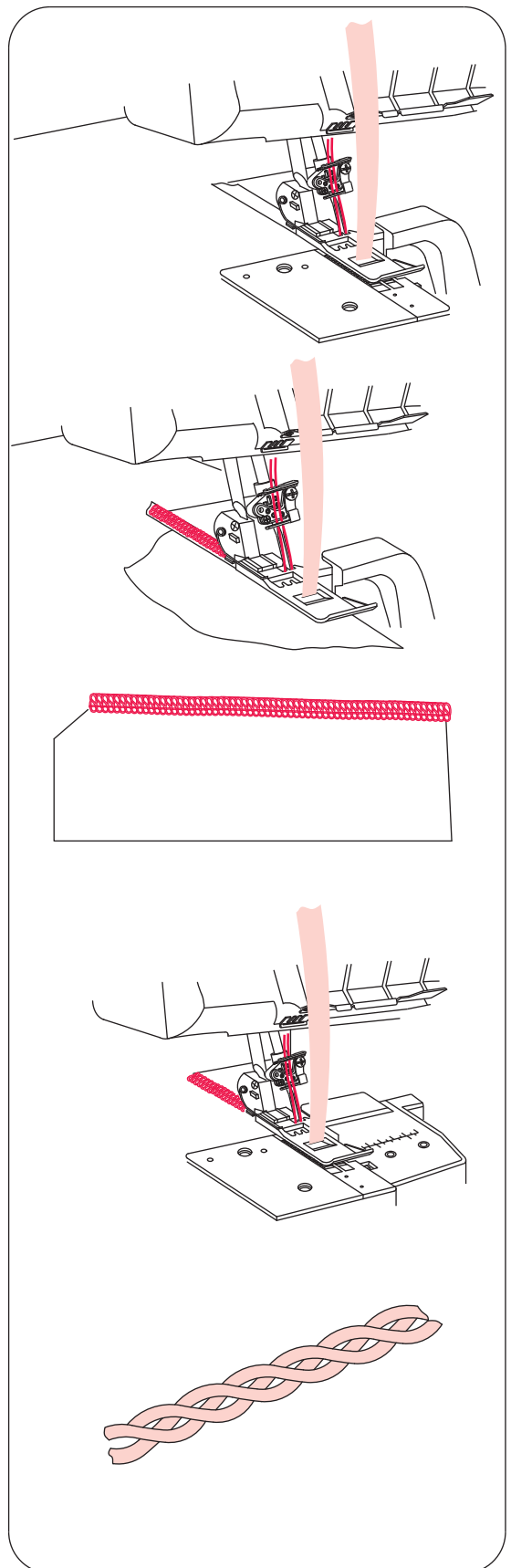

Braiding by Chaining off

- Place the movable upper knife in nonworking position.
- Insert filler cord such as yarn or twill type through the hole in the front of the foot.
- Position the filler cord under the foot and chain off the desired length.
- Chained off braids can be used individually or woven into 3 or 4 ply braids.

26. MACHINE MAINTENANCE

An overlock machine requires more maintenance than a conventional machine for two reasons:

- 1) A lot of lint is produced due to the cutting action of the knives.
- 2) An overlock runs at a very high speed and needs to be oiled frequently to lubricate the internal working parts.

Cleaning the Machine



Danger:

Before cleaning your machine, disconnect power line plug from the wall receptacle.

- Clean the lint from the looper and knife area often with a dry lint brush.

Oiling the Machine



Danger:

Before lubricating your machine, disconnect power line plug from the wall receptacle.

- The oiling points shown in the diagram, should be oiled periodically.

Note: Use only sewing machine oil. Do not use any other oil or damage could result.

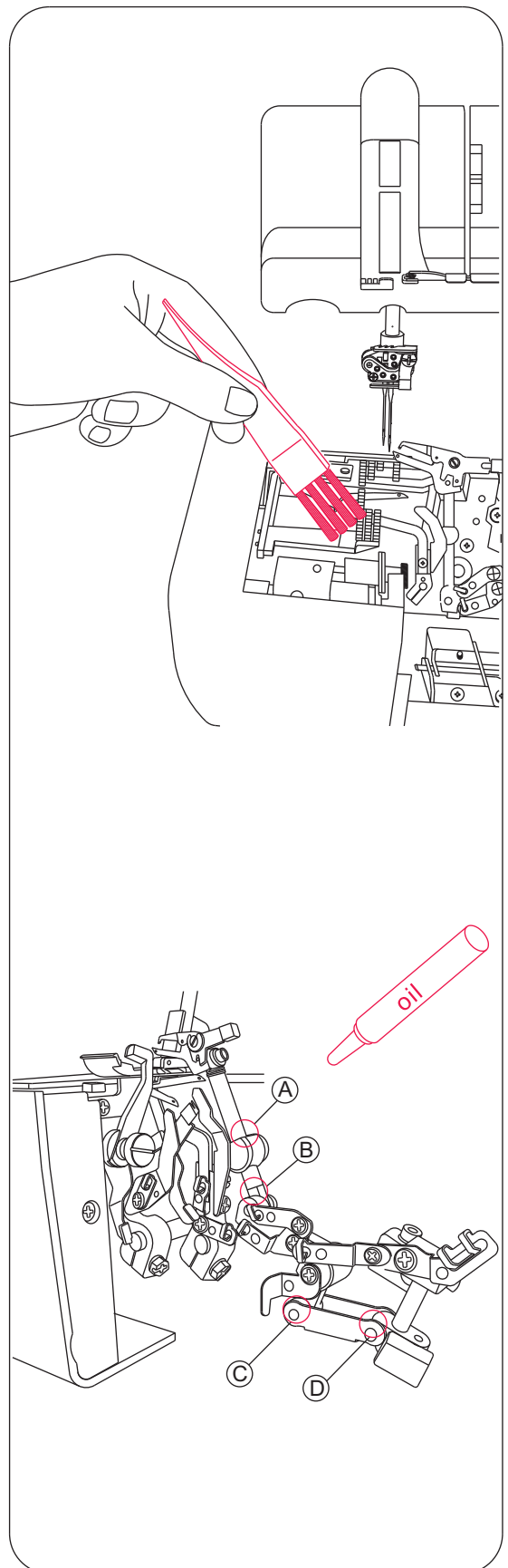

How to Replace the Moveable Upper Knife



Danger:

Before replacing the moveable upper knife, disconnect power line plug from the wall receptacle.

- The moveable upper knife should be changed when it becomes dull.
- The moveable upper knife can be replaced according to the directions provided, however if there are any difficulties experienced, consult your Singer representative to make the replacement.
- Be sure that the power line plug is disconnected from the electric source.
- Open the looper cover and set the moveable upper knife (a) in the working position.
- Loosen the moveable upper knife set screw (b) and remove the moveable upper knife (a).
- Turn the hand wheel to lower the moveable upper knife holder to its lowest position.
- In this position, put a new moveable upper knife in the groove of the moveable upper knife holder, making sure that the edge of the moveable upper knife is approximately 0.5 to 1.0 mm below the surface of the fixed cutting blade (d).
- Tighten moveable upper knife set screw (b).

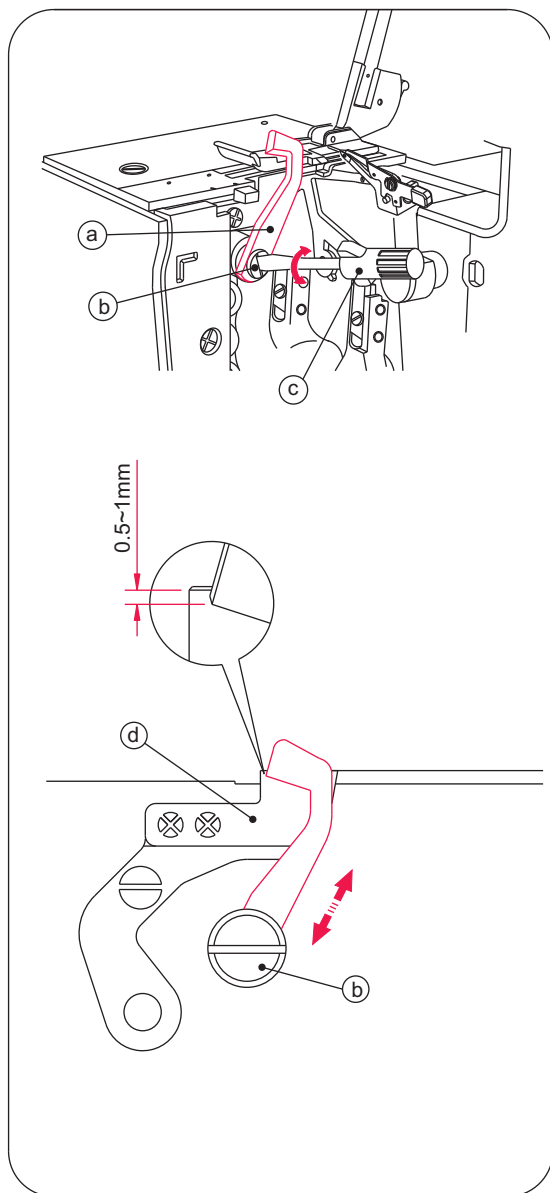

How to Exchange Light Bulb



Danger:

Always unplug before re-lamping.

- Light bulb is available at your Singer shop. Take old bulb to the Singer shop and ask for the same bulb.
- If voltage indicated on the electrical rating plate of your machine is 120V, ask for light bulb conforming to following specification.
 - Bayonet type: 110~120V, 15W
 - Glass shape: T-20
 - Lamp cap: E12
 - Overall length: 48mm
- Remove light cover screw and while pushing the cover lightly to the rear, swing cover to the left and remove from machine as shown in the illustration. Turn bulb to the left to remove. To replace the bulb, push bulb into the socket and turn to the right.



Caution:

Be sure the light bulb has cooled off before changing with a new one.



Warning:

Replace the light cover first before connecting the power line plug.

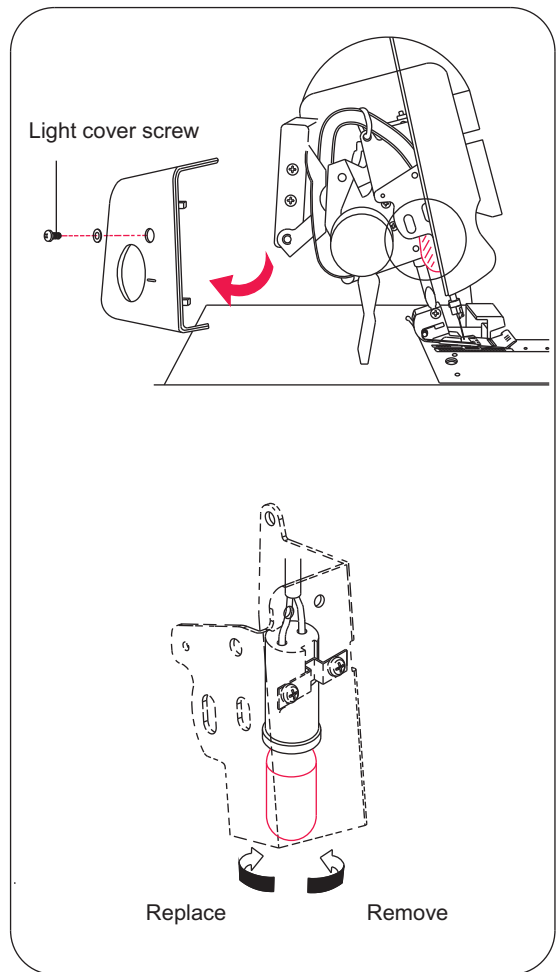

- If voltage indicated on the electrical rating plate of your machine is 220-240V, ask for light bulb conforming to following specification.

-Edison type (screw type): 220 ~240V, 15W

- Glass shape: T-22
 - Lamp cap: E14
 - Overall length: 56mm
- Remove light cover screw and while pushing the cover lightly to the rear, swing cover to the left and remove from machine as shown in the illustration. Turn bulb to the left to remove. To replace the bulb, screw bulb into the socket and turn to the right.

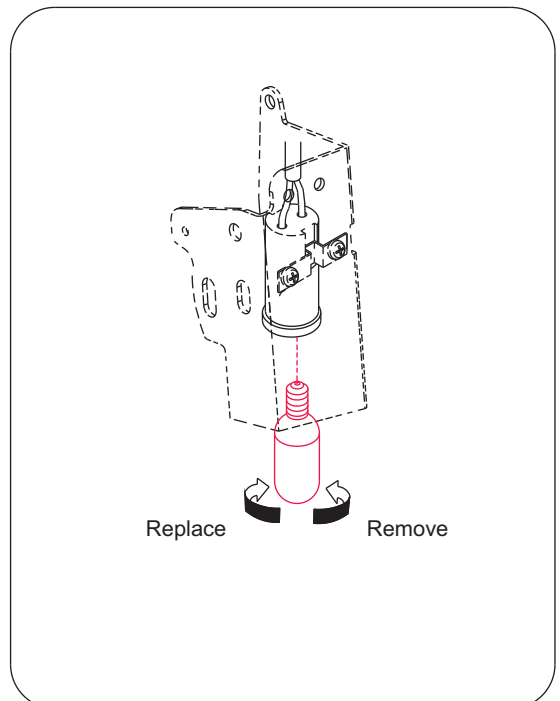

27. OPTIONAL ACCESSORIES

- The following optional presser feet specially prepared for this machine are available at extra-charge.

Note: Do not use presser foot made for other machines. Use of such presser foot may result in interference with the needle and knife and can be hazardous.

- The snap-on type presser foot of this machine permits easy removal and replacement.



Caution:

Be sure to disconnect the power line plug or turn off the power switch when changing the presser foot.

Snap-On Type Presser Foot

Removal

- Raise presser foot by lowering presser bar lifter and raise needle bar to its highest position.
- Press red colored lever (A) located on back of clamp under the presser foot shank, raise presser bar lifter to its High Lift position by pressing down on the presser bar lifter and while holding the presser bar lifter in this position, remove the presser foot plate.

Replacement

- Place presser foot on needle plate under presser foot shank so that hinge pin (C) will fit in slot (B) of the shank. Then lower presser foot by raising presser bar lifter.
- If presser foot can not be placed under presser foot shank easily, raise presser bar by pressing down on the presser bar lifter to its High Lift position and while holding it in this position, place presser foot plate under presser foot shank. Then lower presser by raising presser bar lifter.
- Raise presser bar lifter and make sure the presser foot is properly attached to the presser foot shank.

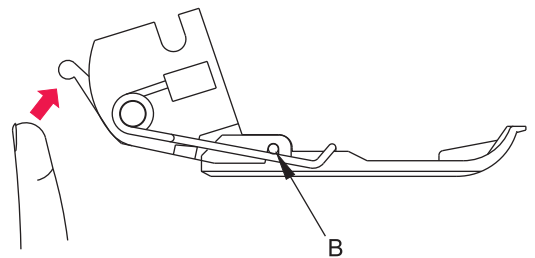
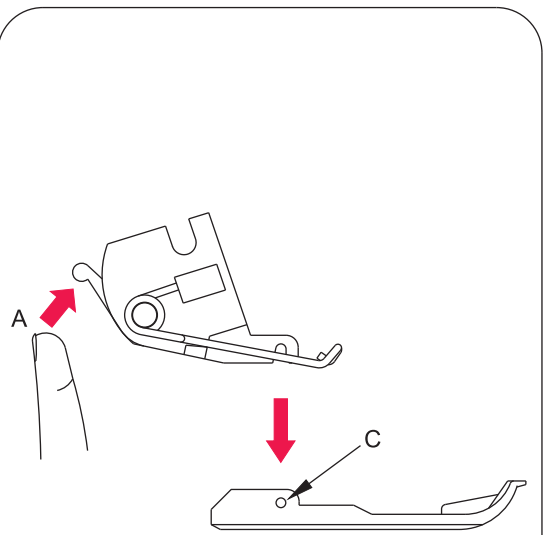

Optional Presser Feet

1) Elastic Foot

- This foot is used for attaching elastic tape to the garment and the amount of contraction of the elastic tape can be adjusted as required.

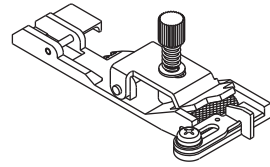

2) Blind Hem Foot

- This foot is for sewing cuffs on knit fabrics, skirt and trouser seams where seam should not be visible.

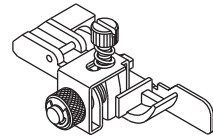

3) Shirring Foot

- This foot is most suited for gathering when sewing tiered skirts, yokes, cuffs and frills on skirts, etc.
- This foot is also suited for sewing two fabrics together and gathering the bottom fabric in one operation.

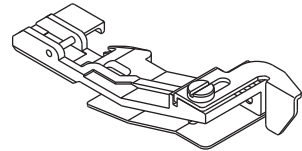

4) Pearl/Sequin Foot

- This foot is used for sewing on beads, etc.

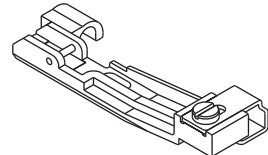

5) Piping/ Cording Foot

- This sewing foot is suited for sewing welting between two plies of fabric.

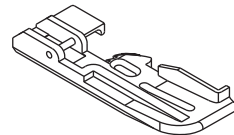

6) Taping Foot

- This sewing foot is suited for sewing on tapes, etc.

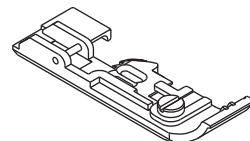

28. TROUBLESHOOTING CHART

Problem	Solution	Page
Fabric does not feed well	- Lengthen stitch length.	31
	- Increase presser foot pressure for heavy weight fabric.	32
	- Decrease presser foot pressure for lightweight fabric.	32
Needle breaks	- Insert needle correctly.	15
	- Do not pull fabric while sewing.	38
	- Tighten needle set screw.	15
	- Use a larger needle on heavy fabrics.	15
Thread breaks	- Check threading.	16~29
	- Check for tangled or caught thread.	30
	- Insert needle correctly.	15
	- Insert new needle, current needle may be bent or have a blunt Point.	9
	- Use only high quality thread.	70
- Loosen thread tension.	34~49	
Stitch skip	- Insert new needles, current needles may be bent or have a blunt point. Use only Singer Branded Style 2022 Needles	9
	- Tighten needle set screw.	15
	- Insert needles correctly.	15
	- Change type or size of needles.	15
	- Check threading.	16~29
	- Increase presser foot pressure.	32
- Use a high quality thread.	70	
Irregular stitches	- Fine tune thread tension.	39~49
	- Check for tangled or caught thread.	30
	- Check threading.	16~29
Fabric puckers	- Loosen thread tension.	39~52
	- Check for tangled or caught thread.	30
	- Use high quality lightweight thread.	70
	- Shorten stitch length.	31
	- Decrease presser foot pressure for lightweight fabrics.	32
Irregular trimming	- Check alignment of knives.	65
	- Replace one or both knives.	65
Fabric jams	- Close looper cover before sewing.	12
	- Check for tangled or caught thread.	30
	- Compress thick layers of fabric with conventional machine before sewing with overlock.	
Machine does not operate	- Connect machine to power source.	12

29. RELATIONSHIP BETWEEN CLOTH, THREAD AND NEEDLE

Type of Fabric	Type of Thread	Needle Singer Cat. #2022
WOVEN		
Lightweight Lawn, Organdy, Voile, Crepe, etc.	Cotton: #100 Silk/ Rayon: #100 Spun: #80 ~ #90 Polyester: #80 ~ #100	#11/80
Medium Weight Muslin, Seersucker, Satin, Gabardine, Broadcloth, etc	Cotton: #60 ~ #80 Silk/ Rayon: #50 Spun: #60 ~ #80 Polyester: #60 ~ #80	#14/90, #11/80
Heavy Weight Oxford, Denim, Tweed, Serge, Corduroy	Cotton: #40 ~ #60 Silk/ Rayon: #40 ~ #60 Spun: #60 ~ #80 Polyester: #50 ~ #80	#14/90
KNIT		
Tricot	Spun: #80 ~ #90 Polyester: #60 ~ #80	#11/80
Jersey	Spun: #60 ~ #80 Polyester: #60 ~ #80 Cotton: #60 ~ #80	#14/90, #11/80
Wool (woven, knit)	Spun: #60 ~ #80 Polyester: #50 ~ #60 Woolly nylon Woolly Polyester	#14/90, #11/80

30. SPECIFICATION

Item	Specification
Sewing speed	1,300 spm maximum
Stitch length (feed amount)	1~4 mm (standard: rolled hemming 1-2, ordinary overedge N=2.5)
Differential feed ratio	1:0.6 ~ 1:2 (with differential feed machine)
Overedge stitch width	Rolled hemming 1.5 mm, ordinary overedge 3.0 ~ 9.8 mm (Standard 4 mm)
Cover stitch needle gauge	Two needles: 2.8 mm (narrow), 5.6 mm (wide) Triple needles: 5.6 mm
Needle bar stroke	27 mm
Pressure foot rise	4.5 mm
Needle	Singer #2022 (EL x 705) #14, #11
Number of threads	2~5
Machine dimensions (mm)	
Width	360
Depth	290
Height	300
Weight (kg)	9.0 kgs

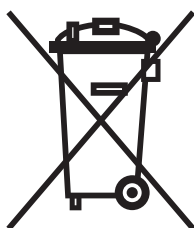

Please note that on disposal, this product must be safely recycled in accordance with relevant National legislation relating to electrical / electronic products. If in doubt please contact your retailer for guidance.

